

## Vibration Motors

**würges**

## Contents

	Page
1. vibration Motors, listed according to speed, power and construction type.	3
2. vibration Motors, in standard execution.	4 – 18
3. vibration Motors, for flange mounting.	19 – 20
4. vibration Motors, for restrictedspace.	21
5. vibration Motors, for 2 power stages, 2 MV system.	22 – 23
6. Frequency converter, request for quotations and recommendations for operation in connection with vibration motors.	24
7. magnetic motors, for dosing tanks.	25
8. vibration Motors, explosion-proof, EEx e II, standard execution.	26 – 27
9. vibration Motors, D.C. or A.C.	28 – 29
10. vibration Motors, for the construction industry 200 Hz.	30 – 31
11. Oscillating Converters for Linear Oscillations.	33 – 34
<b>NEW</b> 12. Page for your notes.	35

The right of performing technical changes which serve the progress will be reserved.



## Vibration Motors listed according to Power, Speed and construction type

Synchrone Speed min. <sup>-1</sup>	Centrif. force daN (kp)	Working-moment cm kg	Model	Page	Line	Synchrone Speed min. <sup>-1</sup>	Centrif. force daN (kp)	Working-moment cm kg	Model	Page	Line		
6000	76	0,40	HF 1/4	200 Hz	30	1000	34	6,10	HV 6/6	10	5		
	305	1,50	HF 6/4		31		98	17,80	HV 6/6-18	10	6		
	1200	6,15	HF 15/4		32		233	42,00	HV 12/6-42	13	5		
3000	305	6,10	HF 6/8	31	2	430	78,00	HV 30/6-75	15	3			
3000	4	0,08	HV 0,1/2	50 or 60 Hz	4	640	115,00	HV 55/6-120	16	3			
	20	0,40	HV 0,4/2		5	1100	200,00	HV 65/6-200	17	3			
	50	1,00	HV 1/2		6	1650	300,00	HV 65/6-300	17	4			
	88	1,85	HV 2/2		7	2200	397,00	HV 85/6-400	17	5			
	132	2,80	HV 2/2-2 *		7+8	1	750	19	6,10	HV 6/8	10	7	
	176	3,70	HV 2/2-4		7+8+9	3/2/1		55	17,80	HV 6/8-18	10	8	
	286	6,00	HV 2/2-6 *		7+8+9	4/3/2		131	42,00	HV 12/8-42	13	6	
	305	6,10	HV 6/2		10+11	1		245	78,00	HV 30/8-75	15	4	
	420	8,40	HV 6/2-8		10	2		362	115,00	HV 55/8-120	16	4	
	420	8,40	HV 8/2 *		12	1		625	200,00	HV 65/8-200	17	5	
	535	10,70	HV 8/2-11		12	2		930	300,00	HV 65/8-300	17	6	
	600	12,00	HV 12/2 *		13	1		1250	397,00	HV 85/8-400	18	6	
	750	15,00	HV 15/2		14	1		3000	600	12,00	HV 12/2 o.F.	21	1
	1050	21,00	HV 15/2-20*		14	2			1500	220	18,00	HV 12/4-18 o.F.	21
	1260	25,00	HV 15/2-25		14	3	375			30,00	HV 12/4-30 o.F.	21	3
	1650	32,00	HV 30/2 *		15	1	525	42,00	HV 12/4-42 o.F.	21	4		
	2500	50,00	HV 55/2 *		16	1	3000	600	12,00	VFL 12/2	20	1	
	3200	65,00	HV 65/2		17	1		1500	220	18,00	VFL 12/4-18	20	2
	4300	86,00	HV 85/2		18	1			375	30,00	VFL 12/4-30	20	3
	6100	123,00	HV 85/2-120		18	2			525	42,00	VFL 12/4-42	20	4
1500	12	1,00	HV 1/4	6	2	3000	4300	86,00	Supermat	19	1-3		
	22	1,85	HV 2/4	7	5	3000	88	1,85	HVE 2/2	26	1		
	33	2,80	HV 2/4-2 *	7	6		132	2,80	HVE 2/2-2	26	2		
	44	3,70	HV 2/4-4	7	7		Εx	176	3,70	HVE 2/2-4	26	3	
	71	6,00	HV 2/4-6 *	7	8			286	6,00	HVE 2/2-6	26	4	
	110	9,00	HV 2/4-9 *	7+9	9/3			600	12,00	HVE 9/2	27	1	
	143	11,50	HV 6/4-11	10	3			1500	22	1,85	HVE 2/4	26	5
	220	17,80	HV 6/4-18 *	10+11	4/2	33	2,80		HVE 2/4-2	26	6		
	220	18,00	HV 12/4-18	13	2	44	3,70		HVE 2/4-4	26	7		
	375	30,00	HV 12/4-30	13	3	71	6,00		HVE 2/4-6	26	8		
	525	42,00	HV 12/4-42*	13	4	110	9,00		HVE 2/4-9	26	9		
	980	78,00	HV 30/4-75	15	2	220	18,00		HVE 9/4-18	27	2		
	1450	115,00	HV 55/4-120	16	2	375	30,00		HVE 9/4-30	27	3		
	2500	200,00	HV 65/4-200	17	2	6000	Electromagnetic Vibrator	MR 1	25	1+2			
	5000	397,00	HV 85/4-300	18	3	5000	A.C. Vibration Motor	HV 6 W	28	1			
	5000	397,00	HV 85/4-400	18	4	3300	D.C. Vibration Motor	HV 6 GL	=	29 1+2			
						Accessories	Oscillating Converter	SR 2 – SR 55	33	1-4			

\* Available with 2 MV balance system:

Two vibrations forces with equal speed in one unit without the need of assembly. See Page 22 + 23



## Monophase A.C. Vibration Motor



A very small compact unit, requiring minimum space. No adjustment of the centrifugal force. With the admitted current input this vibrator can be run continuously. The sturdy case is manufactured from aluminium chill casting. It is not lacquered.

3 ft. connection cable 3 x 0,75 mm<sup>2</sup>, ø 7mm, ÖLFLEX®-540P

Protection class IP 65 · Insulant class E

Admitted voltages: 200 – 240 vs. 50 cps.  
200 – 254 vs. 60 cps.

Line	Model	Synchron.	Centrif.	Working-	Changing of the	Standard voltage	Nominal	Power
		Speed				50 – 60 Hz		
		min <sup>-1</sup>	daN	cm kg	cannot be changed	V	A	W
1	HV 0,1/2	3000	4	0,08	cannot be changed	1 ~ 230	0,11	25

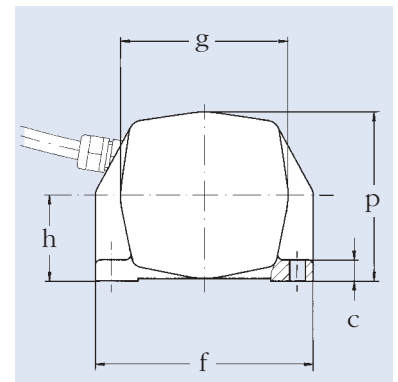
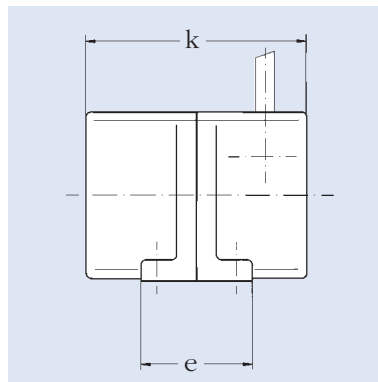
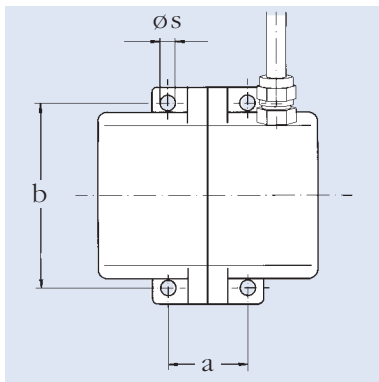

Model	Bores for fastening			Base measurements			outside measurements				Mass
	mm			mm			mm				
	a	b	ø <sub>s</sub>	c	e	f	h	g	p	k	
HV 0,1/2	30	70	6	8	42	82	32,5	63	64	83	0,97



## Threephase Vibration Motor

The sturdy housing is manufactured from aluminium chill casting. The amply dimensioned bearings 629 ZZ C3 are lubricated for life. The centrifugal force can be changed stepwise by taking off the eccentric weights. The vibrator can be run continuously with all the eccentric weights mounted, under consideration of the admissible power consumption.

Standard voltage 400 vs. · 50 cps. or 230 vs. · 50 cps. Other voltages are available.

The motor has no commutable poles. For operation with a 230vs.-A.C. power supply source an operating capacitor of 2µF can be delivered.

Type of protection IP 65 · Insulant class F



Line	Model	Synchron. speed min <sup>-1</sup>	Centrif. force daN	Working moment cm kg	Changing of the centrifugal force		Standard voltage 50 cps. V	Nominal current A	Power input W
					inf. vari.	stepwise			
1	HV 0,4/2	3000	20	0,4	–	4 ▲	3 ~ 400	0,1	50

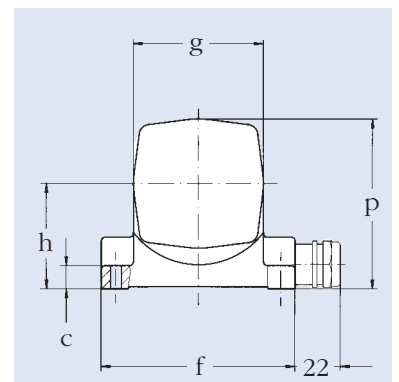
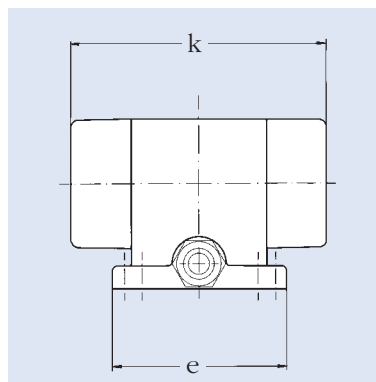
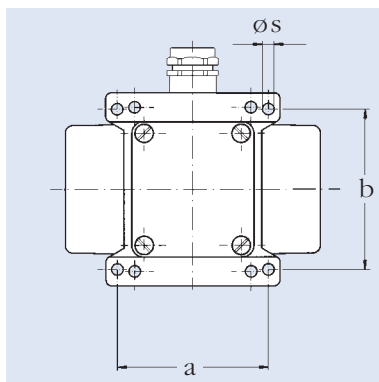

Model	Bores for fastening <sup>1</sup> mm			Base measurements mm			Outside measurements mm				Mass kg
	a	b	ø <sub>s</sub>	c	e	f	h	g	p	k	
HV 0,4/2	$\left\{ \begin{array}{ccc} 60 & 85 & 6 \\ 78 & 83 & 6 \end{array} \right\}$			12	90	100	54,5	67	88	132	1,9

<sup>1</sup> All mentioned fastening holes are provided in the unit.





## Threephase Vibration Motor

The sturdy housing is manufactured from aluminium chill casting. The amply dimensioned bearings 6302 2Z C4 are lubricated for life. The centrifugal force can be changed stepwise by taking off the eccentric weights. The vibrator can be run continuously with all the eccentric weights mounted, under consideration of the admissible power consumption.

Standard voltage 230/400vs.·50cps. Other voltages are available.

For operation with a 230vs.-A.C. power supply source an operating capacitor of 4µF can be delivered.

Type of protection IP 65·Insulant class F

Line	Model	Synchron. speed min <sup>-1</sup>	Centrif. force daN	Working moment cm kg	Changing of the centrifugal force		Standard voltage 50 cps. V	Nominal current A	Power input W
					inf. vari.	stepwise			
1	HV 1/2	3000	50	1	–	5 ▲	3 ~ 230/400	0,30/0,17	95
2	HV 1/4	1500	12,5	1	–	5 ▲	3 ~ 230/400	0,23/0,13	60

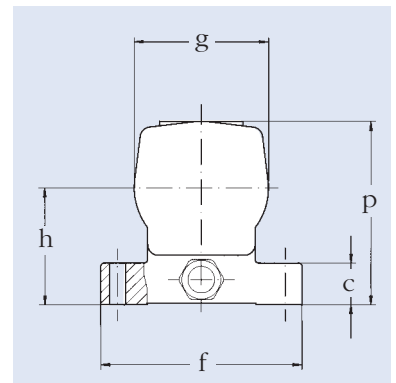
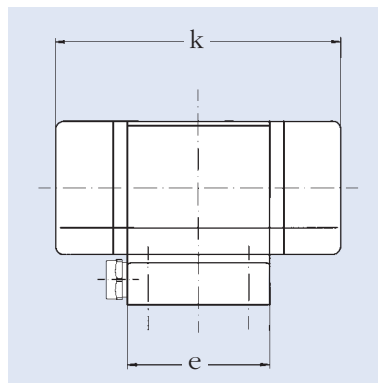
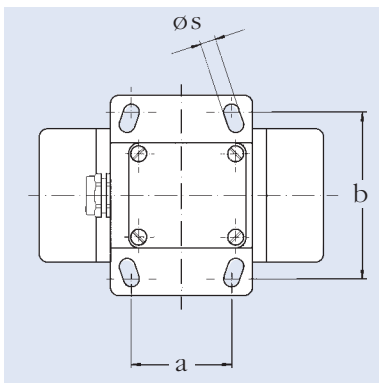

Model	Bores for fastening <sup>1</sup> mm			Base measurements mm			Outside measurements mm				Mass kg
	a	b	Ø <sub>s</sub>	c	e	f	h	g	p	k	
HV 1/2	60	100	9,5	25	85	120	70	80	110	170	3,6
HV 1/4											

<sup>1</sup> All mentioned fastening holes are provided in the unit.



## Threephase Vibration Motor

The sturdy housing is manufactured from aluminium chill casting. The amply dimensioned bearings 6302 2Z C4 are lubricated for life. The centrifugal force can be changed stepwise by taking off the eccentric weights. The vibrator can be run continuously with all the eccentric weights mounted, under consideration of the admissible power consumption.

Standard voltage 230/400 vs. 50cps. Other voltages available.

\* These bipolar units are also available as extra executions of 1~230 vs., 50 cps.

A.C. For this, an operating capacitor of 7µF can be delivered.

All HV 2 rotary current units can be delivered also in protection class EEx e II T3. (See page 26). Type of protection IP 65 · Insulant class F



Line	Model	Synchron. speed min <sup>-1</sup>	Centrif. force daN	Working moment cm kg	Changing of the centrifugal force		Standard voltage 50 cps. V	Nominal current A	Power input W
					inf. vari.	stepwise			
1	HV 2/2*	3000	88	1,85	–	4 ▲	3 ~ 230/400	0,49/0,29	160
2	HV 2/2-2*	3000	132	2,8	–	6 ▲	3 ~ 230/400	0,49/0,29	160
3	HV 2/2-4*	3000	176	3,7	–	8 ▲	3 ~ 230/400	0,49/0,29	160
4	HV 2/2-6*	3000	286	6	–	13 ▲	3 ~ 230/400	0,49/0,29	160
5	HV 2/4	1500	22	1,85	–	4 ▲	3 ~ 230/400	0,57/0,33	140
6	HV 2/4-2	1500	33	2,8	–	6 ▲	3 ~ 230/400	0,57/0,33	140
7	HV 2/4-4	1500	44	3,7	–	8 ▲	3 ~ 230/400	0,57/0,33	140
8	HV 2/4-6	1500	71,5	6	–	13 ▲	3 ~ 230/400	0,57/0,33	140
9	HV 2/4-9	1500	110	9	–	20 ▲	3 ~ 230/400	0,57/0,33	140

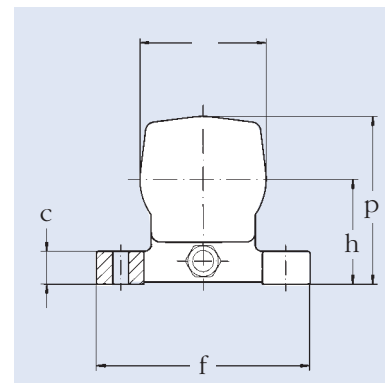
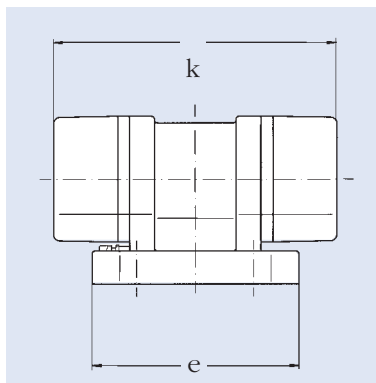
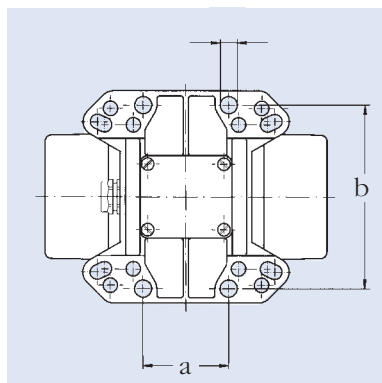

Model HV	Bores for fastening <sup>1</sup> mm			Base measurements mm			Outside measurements mm				Mass kg
	a	b	ø <sub>S</sub>	c	e	f	h	g	p	k	
2/•	$\left. \begin{matrix} 65 & 140 & 13 \\ 80 & 110 & 11 \\ 115 & 135 & 11 \\ 135 & 115 & 11 \\ 124 & 110 & 11 \end{matrix} \right\}$	25	157	162	80	96	128	189	5,2		
2/•-2		25	157	162	80	96	128	201	5,5		
2/•-4		25	157	162	80	96	128	215	6,0		
2/•-6		25	157	162	80	96	128	250	6,7		
2/4-9		25	157	162	80	96	128	283	7,7		

<sup>1</sup> All mentioned fastening holes are provided in the unit.





## Threephase Vibration Motor

The sturdy housing is manufactured from aluminium chill casting. The amply dimensioned bearings 6302 2Z C4 are lubricated for life. The centrifugal force can be changed stepwise by taking off the eccentric weights. The vibrator can be run continuously with all the eccentric weights mounted, under consideration of the admissible power consumption.

Standard voltage 230/400vs. · 50cps. Other voltages are available.

The units are also available for extra executions of 1~230 vs. · 50 cps. A.C. For this, an operating capacitor of 7µF can be delivered.

Type of protection IP 65 · Insulant class F

Line	Model	Synchron. speed min <sup>-1</sup>	Centrif. force daN	Working moment cm kg	Changing of the centrifugal force		Standard voltage 50 cps. V	Nominal current A	Power input W
					inf. vari.	stepwise			
1	HV 2/2-2BC	3000	132	2,8	–	6 ▲	3 ~ 230/400	0,49/0,29	160
2	HV 2/2-4BC	3000	176	3,7	–	8 ▲	3 ~ 230/400	0,49/0,29	160
3	HV 2/2-6BC	3000	286	6	–	13 ▲	3 ~ 230/400	0,49/0,29	160

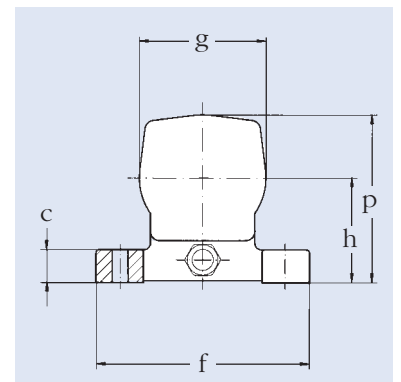
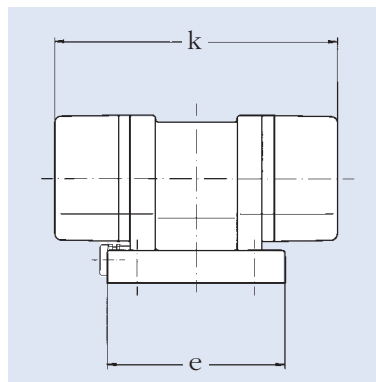
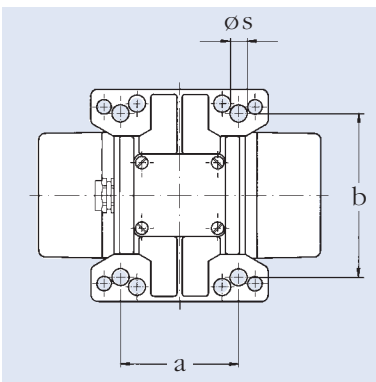

Model HV	Bores for fastening <sup>1</sup> mm			Base measurements mm			Outside measurements mm				Mass kg
	a	b	ø <sub>s</sub>	c	e	f	h	g	p	k	
2/2-4 BC	65	140	13	25	135	162	80	96	128	215	6,0
2/2-6 BC	115	135	11	25	135	162	80	96	128	250	6,7

<sup>1</sup> All mentioned fastening holes are provided in the unit.





## Threephase Vibration Motor

The sturdy housing is manufactured from aluminium chill casting. The amply dimensioned bearings 6302 2Z C4 are lubricated for life. The centrifugal force can be changed stepwise by taking off the eccentric weights. The vibrator can be run continuously with all the eccentric weights mounted, under consideration of the admissible power consumption.

Standard voltage 230/400vs. · 50cps. Other voltages are available.

\*These units are also available for extra executions of 1~230 vs. · 50 cps. A.C. For this, an operating capacitor of 7µF can be delivered.

Type of protection IP 65 · Insulant class F



Line	Model	Synchron. speed min <sup>-1</sup>	Centrif. force daN	Working moment cm kg	Changing of the centrifugal force		Standard voltage 50 cps. V	Nominal current A	Power input W
					inf. vari.	stepwise			
1	HV 2/2-4B2*	3000	176	3,7	–	8 ▲	3 ~ 230/400	0,49/0,29	160
2	HV 2/2-6B2*	3000	286	6	–	13 ▲	3 ~ 230/400	0,49/0,29	160
3	HV 2/4-9B2	1500	110	9	–	20 ▲	3 ~ 230/400	0,57/0,33	140

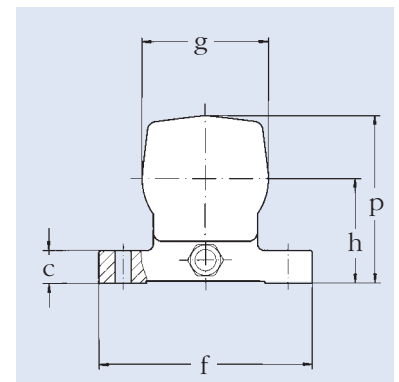
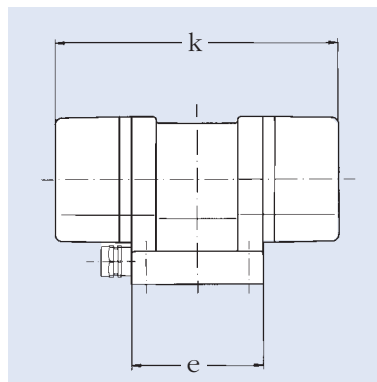
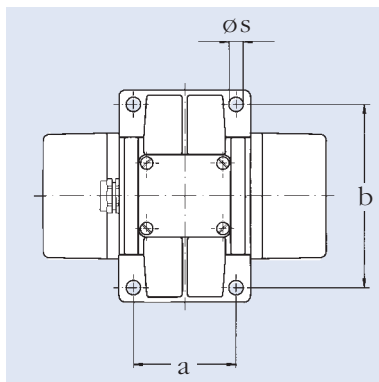

Model HV	Bores for fastening mm			Base measurements mm			Outside measurements mm				Mass kg
	a	b	ø <sub>s</sub>	c	e	f	h	g	p	k	
2/2-4 B2	78	140	11	25	100	162	80	96	128	215	5,9
2/2-6 B2	78	140	11	25	100	162	80	96	128	250	6,6
2/4-9 B2	78	140	11	25	100	162	80	96	128	283	7,6





## Threephase Vibration Motor

The sturdy housing is manufactured from aluminium chill casting. The amply dimensioned bearings 6303 2Z C4 are lubricated for life. The centrifugal force can be changed by means of mountable eccentric weights. The vibrator can be run continuously with all the eccentric weights mounted, under consideration of the admissible power input. (\*exception: type HV 6/2-8 with 40 % connection time) Standard voltage 230/400vs.·50cps. Other voltages are available.

Type HV 6/2 (Line 1) is also available as special-made execution for 1~ 230vs. · 50cps. A.C. with reduced centrifugal force of 70 %. For this, an operating capacitor of 10µF can be delivered.

Type of protection IP 65 · Insulant class F

Line	Model	Synchron. speed min <sup>-1</sup>	Centrif. force daN	Working moment cm kg	Changing of the centrifugal force		Standard voltage 50 cps. V	Nominal current A	Power input W
					inf. vari.	stepwise			
1	HV 6/2	3000	305	6,1	–	8 ▲	3 ~ 230/400	0,99/0,57	300
2	HV 6/2-8*	3000	420	8,4	–	11 ▲	3 ~ 230/400	1,2/0,7	350
3	HV 6/4-11	1500	143	11,5	–	15 ▲	3 ~ 230/400	0,75/0,43	190
4	HV 6/4-18	1500	220	17,8	–	23 ▲	3 ~ 230/400	0,75/0,43	190
5	HV 6/6	1000	34	6,1	–	8 ▲	3 ~ 230/400	0,78/0,45	150
6	HV 6/6-18	1000	98	17,8	–	23 ▲	3 ~ 230/400	0,78/0,45	150
7	HV 6/8	750	19	6,1	–	8 ▲	3 ~ 230/400	0,54/0,31	120
8	HV 6/8-18	750	55	17,8	–	23 ▲	3 ~ 230/400	0,54/0,31	120

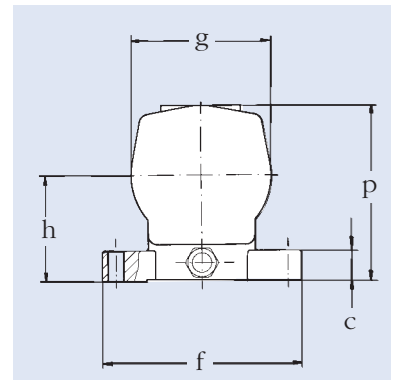
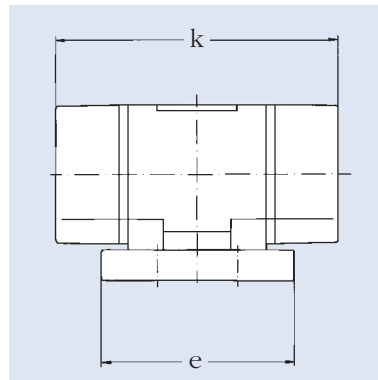
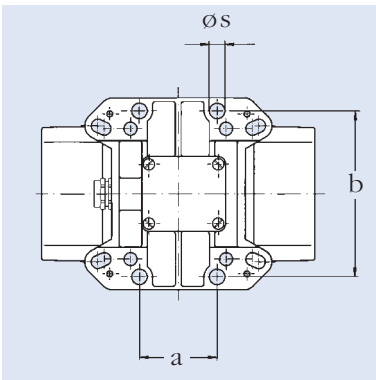

Model	Bores for fastening <sup>1</sup> mm			Base measurements mm			Outside measurements mm				Mass kg	
	a	b	ø <sub>s</sub>	c	e	f	h	g	p	k		
HV 6/2	65	140	13	25	157	162	86	114	144	230	7,5	
HV 6/2-8		110	11	25	157	162	86	114	144	270	8,7	
HV 6/4-11		(115	135	11)	25	157	162	86	114	144	270	9,0
HV 6/4-18			135	11	25	157	162	86	114	144	320	11,0
HV 6/•		124	110	11	25	157	162	86	114	144	230	8,0
HV 6/•-18					25	157	162	86	114	144	320	11,5

<sup>1</sup> All mentioned fastening holes are provided in the unit.



## Threephase Vibration Motor

The sturdy housing is manufactured from aluminium chill casting. The amply dimensioned bearings 6303 2Z C4 are lubricated for life. The centrifugal force can be changed stepwise by taking off the eccentric weights. The vibrator can be run continuously with all the eccentric weights mounted, under consideration of the admissible power consumption.

Standard voltage 230/400vs. · 50cps. Other voltages are available.

Type of protection IP 65 · Insulant class F



Line	Model	Synchron. speed min <sup>-1</sup>	Centrif. force daN	Working moment cm kg	Changing of the centrifugal force		Standard voltage 50 cps. V	Nominal current A	Power input W
					inf. vari.	stepwise			
1	HV 6/2 H	3000	305	6,1	–	8 ▲	3 ~ 230/400	0,99/0,57	300
2	HV 6/4-18 H	1500	220	17,8	–	23 ▲	3 ~ 230/400	0,75/0,43	190

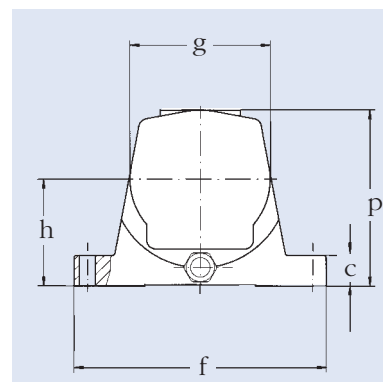
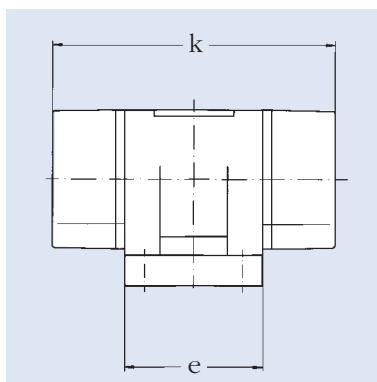
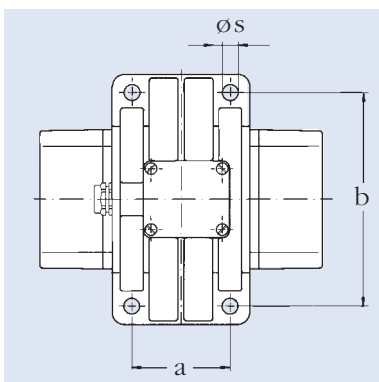

Model	Bores for fastening mm			Base measurements mm			Outside measurements mm				Mass kg
	a	b	Ø <sub>S</sub>	c	e	f	h	g	p	k	
6/2 H	80	175	13	25	115	205	86	114	144	230	7,5
6/4-18 H	80	175	13	25	115	205	86	114	144	320	11,0





## Threephase Vibration Motors

The extremely sturdy housing is manufactured from highly resistant, heat treated aluminium chill casting. The bearings NJ 2304 C4 which are lubricated with special grease, i.e. UNIREX N3, make sure an impeccable function and long life. The centrifugal force can be changed by means of mountable eccentric weights. The vibrator can be run continuously with all the eccentric weights mounted, under consideration of the admissible power input.

\* An exception is type HV 8/2-11. This unit is a special execution and should be used only with storage bins for facilitating the delivery.  
Mounted bearings: 6303 2Z C4 are lubricated for life.

Standard voltage 230/400vs.·50cps. Other voltages are available.  
Type of protection IP 65·Insulant class F

Line	Model	Synchron. speed min <sup>-1</sup>	Centrif. force daN	Working moment cm kg	Changing of the centrifugal force		Standard voltage 50 cps. V	Nominal current A	Power input W
					inf. vari.	stepwise			
1	HV 8/2	3000	420	8,4	–	11 ▲	3 ~ 230/400	1,65/0,95	540
2	HV 8/2-11*	3000	535	10,7	–	14 ▲	3 ~ 230/400	1,65/0,95	540

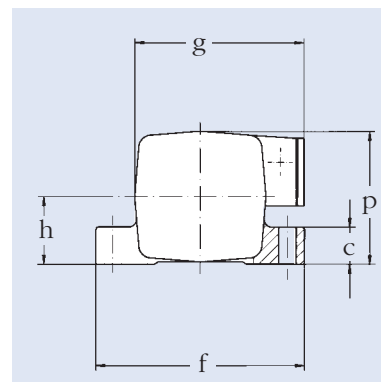
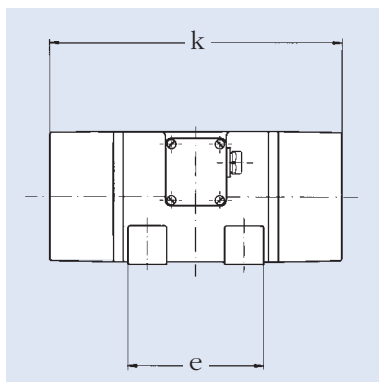
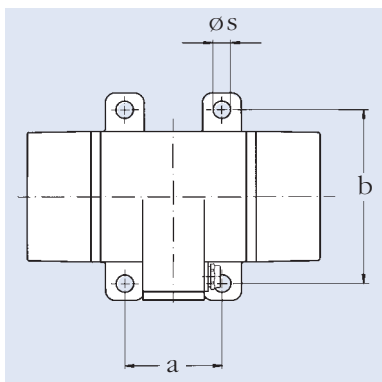

Model	Bores for fastening mm			Base measurements mm			Outside measurements mm				Mass kg
	a	b	ø <sub>s</sub>	c	e	f	h	g	p	k	
HV 8/2	100	180	18	35	130	210	65	165	124	288	12,0
HV 8/2-11	100	180	18	35	130	210	65	165	124	275	11,5



## Threephase Vibration Motors

The extremely sturdy housing is manufactured from highly resistant, heat treated aluminum chill casting. The amply dimensioned bearings 6305 2Z C4 are lubricated for life. The centrifugal force can be changed by means of mountable eccentric weights. The vibrator can be run continuously with all the eccentric weights mounted, under consideration of the admissible power input.



Standard voltage 230/400vs. · 50cps. Other voltages are available.  
Type of protection IP 65 · Insulant class F

- 1) These units are also available as protection type EEx e II T4. See page 27.
  - 2) These units are also available in extremely narrow construction. See page 21.
- In addition, these units are also available for flange fastening. See page 20.

Line	Model	Synchron. speed min <sup>-1</sup>	Centrif. force daN	Working moment cm kg	Changing of the centrifugal force		Standard voltage 50 cps. V	Nominal current A	Power input W
					inf. vari.	stepwise			
1	HV 12/2 <sup>1,2</sup>	3000	600	12	–	8 ▲	3 ~ 230/400	2,16/1,25	650
2	HV 12/4-18 <sup>1,2</sup>	1500	220	18	–	12 ▲	3 ~ 230/400	1,43/0,83	450
3	HV 12/4-30 <sup>1,2</sup>	1500	375	30	–	20 ▲	3 ~ 230/400	1,43/0,83	450
4	HV 12/4-42 <sup>2</sup>	1500	525	42	–	15 ▲	3 ~ 230/400	1,43/0,83	450
5	HV 12/6-42	1000	223	42	–	15 ▲	3 ~ 230/400	1,12/0,65	300
6	HV 12/8-42	750	131	42	–	15 ▲	3 ~ 230/400	1,0/0,6	250

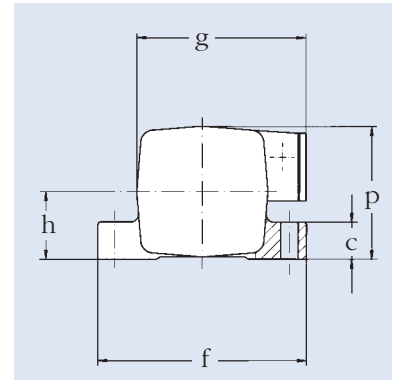
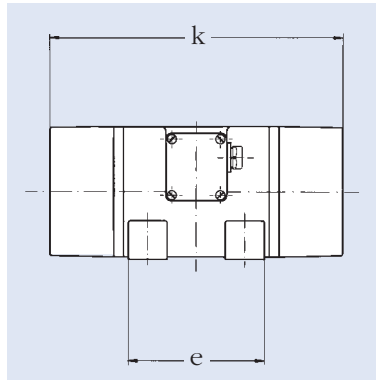
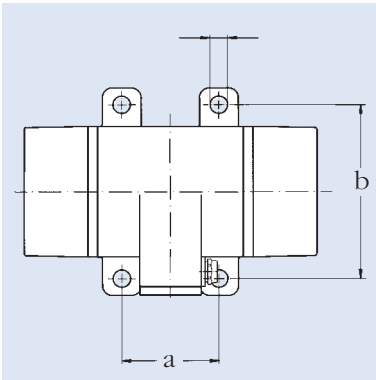

Model HV	Bores for fastening mm			Base measurements mm			Outside measurements mm				Mass kg
	a	b	ø <sub>S</sub>	c	e	f	h	g	p	k	
12/2	100	180	18	40	140	215	70	175	138	303	15
12/4-18	100	180	18	40	140	215	70	175	138	303	15,5
12/4-30	100	180	18	40	140	215	70	175	138	350	18,8
12/•-42	100	180	18	50	140	215	80	186	159	330	21





## Threephase Vibration Motors

The extremely sturdy housing is manufactured from highly resistant, heat treated aluminium chill casting. The bearings NJ 2305 E C4 which are lubricated with special grease, make sure impeccable operation for a long time. The centrifugal force can be changed stepwise by taking off the eccentric weights. The vibrator can be run continuously under consideration of the admissible power input..

Standard voltage 230/400vs. · 50cps. Other voltages are available.

Type of protection IP 65 · Insulant class F

Line	Model	Synchron. speed min <sup>-1</sup>	Centrif. force daN	Working moment cm kg	Changing of the centrifugal force		Standard voltage 50 cps. V	Nominal current A	Power input W
					inf. vari.	stepwise			
1	HV 15/2	3000	750	15	–	10 ▲	3 ~ 230/400	2,16/1,25	650
2	HV 15/2-20	3000	1050	21	–	14 ▲	3 ~ 230/400	2,7/1,55	900
3	HV 15/2-25	3000	1260	25	–	10 ▲	3 ~ 230/400	2,7/1,55	900

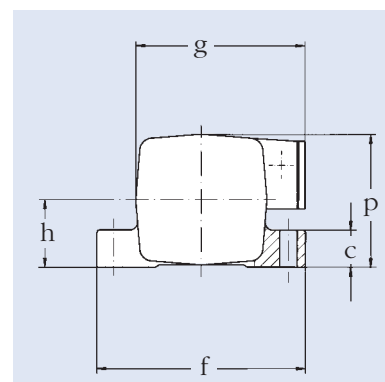
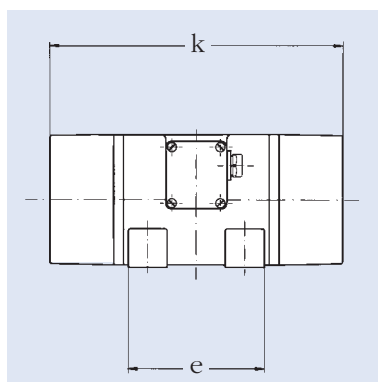
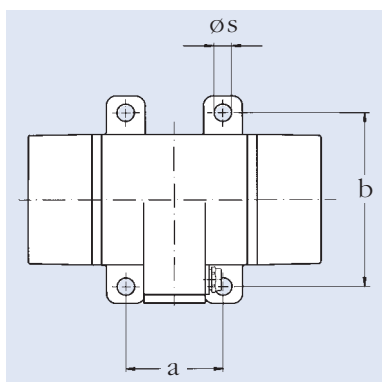

Model	Bores for fastening mm			Base measurements mm			Outside measurements mm				Mass kg
	a	b	ø <sub>s</sub>	c	e	f	h	g	p	k	
HV 15/2	100	180	18	40	140	215	70	175	138	303	16,3
HV 15/2-20	100	180	18	40	140	215	70	175	138	350	18
HV 15/2-25	100	180	18	50	140	215	80	186	159	330	19



## Threephase Vibration Motors

The extremely sturdy housing is manufactured from highly resistant, heat treated aluminium chill casting. The bearings NJ 2206 C4 which are lubricated with special grease, make sure impeccable operation for a long time. The centrifugal force of the bipolar vibrator can be regulated stepwise by means of mountable eccentric weights. The other vibrator types are infinitely variable. Under consideration of the admissible power absorption the vibrator can be run continuously.



Standard voltage 230/400vs. · 50cps. Other voltages are available.

Type of protection IP 65 · Insulant class F

Line	Model	Synchron. speed min <sup>-1</sup>	Centrif. force daN	Working moment cm kg	Changing of the centrifugal force		Standard voltage 50 cps. V	Nominal current A	Power input W
					inf. vari.	stepwise			
1	HV 30/2	3000	1650	32	–	14 ▲	3 ~ 230/400	2,9/1,7	1000
2	HV 30/4-75	1500	980	78	2 ◀	–	3 ~ 230/400	2,5/1,43	800
3	HV 30/6-75*	1000	430	78	2 ◀	–	3 ~ 230/400	2,1/1,2	550
4	HV 30/8-75*	750	245	78	2 ◀	–	3 ~ 230/400	1,65/0,95	370

\* Used bearings: 6305 2Z C4 lubricated for life.

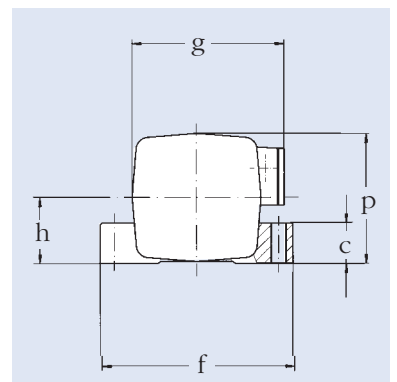
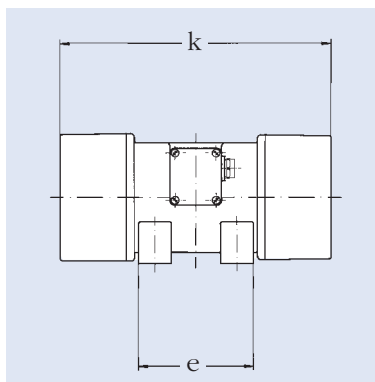
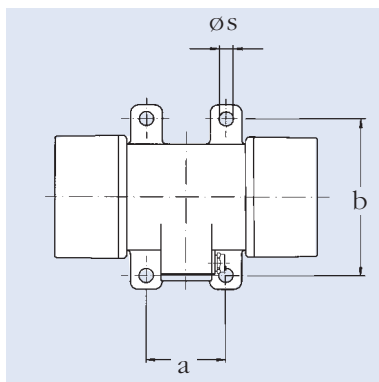

Model HV	Bores for fastening mm			Base measurements mm			Outside measurements mm				Mass kg
	a	b	ø <sub>s</sub>	c	e	f	h	g	p	k	
30/2	100	200	18	50	140	235	82	195	161	330	22,5
30/•-75	100	200	18	50	140	235	82	195	161	430	31





## Threephase Vibration Motors

The extremely sturdy housing is manufactured from highly resistant, heat treated aluminium chill casting. The bearings NJ 407 M C4 which are lubricated with special grease, make sure impeccable operation for a long time. The centrifugal force of the bipolar vibrator can be regulated stepwise by means of mountable eccentric weights. The other vibrator types are infinitely variable. Under consideration of the admissible power absorption the vibrator can be run continuously.

Standard voltage 230/400vs. · 50cps. Other voltages are available.

Type of protection IP 65 · Insulant class F

Line	Model	Synchron. speed min <sup>-1</sup>	Centrif. force daN	Working moment cm kg	Changing of the centrifugal force		Standard voltage 50 cps. V	Nominal current A	Power input W
					inf. vari.	stepwise			
1	HV 55/2	3000	2500	50	–	12 ▲	3 ~ 230/400	6,6/3,8	2100
2	HV 55/4-120	1500	1450	115	2 ▲	–	3 ~ 230/400	3,1/1,8	950
3	HV 55/6-120	3000	640	115	2 ▲	–	3 ~ 230/400	2,4/1,4	690
4	HV 55/8-120	750	362	115	2 ▲	–	3 ~ 230/400	2,1/1,2	500

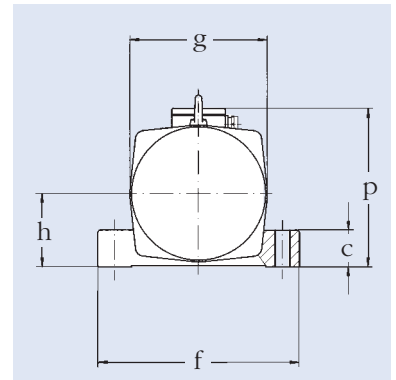
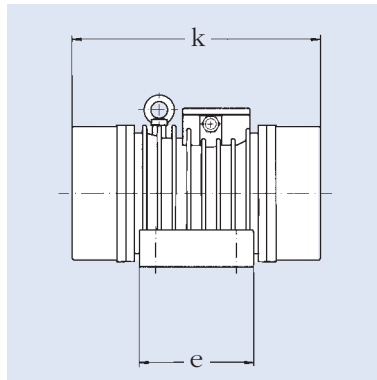
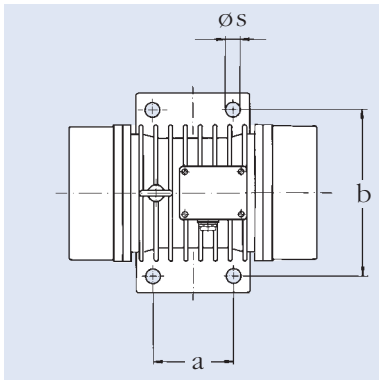

Model HV	Bores for fastening mm			Base measurements mm			Outside measurements mm				Mass kg
	a	b	ø <sub>s</sub>	c	e	f	h	g	p	k	
55/2	120	250	22	55	170	300	110	205	240	370	43
55/•-120	120	250	22	55	170	300	110	205	240	430	54





## Threephase Vibration Motors

The centrifugal force is transmitted to the equipment to be vibrated directly through the extremely sturdy shields covering the bearings and forming the base of the vibrator. The motor housing is manufactured from highly resistant, heat treated aluminium chill casting. The special bearings NJ 407 C4 or TMB 6407 C4 which are lubricated with special grease, make sure impeccable operation for a long time. The centrifugal force is infinitely variable. Under consideration of the admissible power absorption the vibrator can be run continuously. The measurements of the fastening holes are identical to those of the HV 55 vibrators.



Standard voltage 230/400vs.·50cps. Other voltages are available.

Type of protection IP 65·Insulant class F

Line	Model	Synchron. speed min <sup>-1</sup>	Centrif. force daN	Working moment cm kg	Changing of the centrifugal force		Standard voltage 50 cps.		Nominal current A	Power input W
					inf. vari.	stepwise	V			
1	HV 65/2*	3000	3200	65	2	–	3 ~	230/400	6,6/3,8	2100
2	HV 65/4-200	1500	2500	200	2	–	3 ~	230/400	4,7/2,7	1400
3	HV 65/6-200	1000	1100	200	2	–	3 ~	230/400	3,1/1,8	850
4	HV 65/6-300	1000	1650	300	2	–	3 ~	230/400	3,1/1,8	850
5	HV 65/8-200	750	625	200	2	–	3 ~	230/400	2,1/1,2	500
6	HV 65/8-300	750	930	300	2	–	3 ~	230/400	2,1/1,2	500

\* Fitted with bearings of the typeNJ 407 M C4.

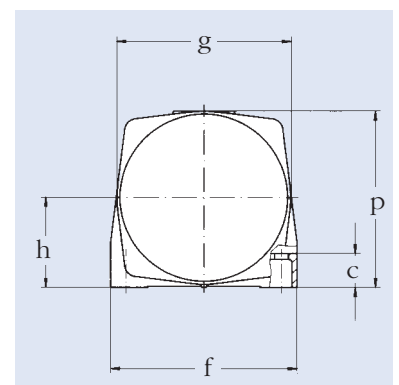
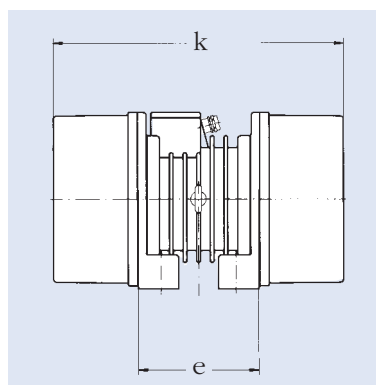
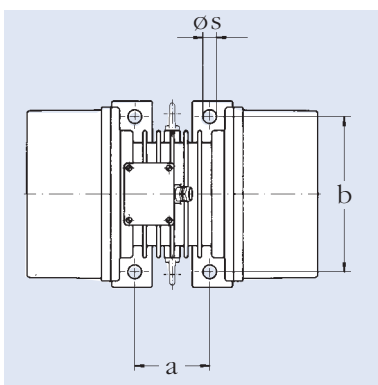

Model	Bores for fastening mm			Base measurements mm			Outside measurements mm				Mass kg	
	HV	a	b	ø <sub>s</sub>	c	e	f	h	g	p		k
65/2		120	250	22	55	200	300	145	280	285	368	?
65/•-200		120	250	22	55	200	300	145	280	285	368	?
65/•-300		120	250	22	55	200	300	145	280	285	468	80





## Threephase Vibration Motors

The extremely sturdy housing is manufactured from highly resistant, heat treated aluminium chill casting. The bearings NJ 407 C4 which are lubricated with special grease, make sure impeccable operation for a long time. The centrifugal force is infinitely variable. Under consideration of the admissible power absorption the vibrator can be run continuously.

\* Exeption: type HV 85/2-120 with 40 % connection time.

Standard voltage 230/400vs. 50cps. Other voltages are available.

Type of protection IP 65 · Insulant class F

Line	Model	Synchron. speed min <sup>-1</sup>	Centrif. force daN	Working moment cm kg	Changing of the centrifugal force		Standard voltage 50 cps.		Nominal current A	Power input W
					inf. vari.	stepwise	V			
1	HV 85/2	3000	4300	86	2	—	3 ~	230/400	12,0/6,9	4200
2	HV 85/2-120*	3000	6100	123	2	—	3 ~	230/400	12,0/6,9	4200
3	HV 85/4-300	1500	3700	300	2	—	3 ~	230/400	6,4/3,7	2000
4	HV 85/4-400	1500	5000	397	2	—	3 ~	230/400	6,4/3,7	2000
5	HV 85/6-400	1000	2200	397	2	—	3 ~	230/400	5,5/3,2	1500
6	HV 85/8-400	750	1250	397	2	—	3 ~	230/400	3,8/2,2	950

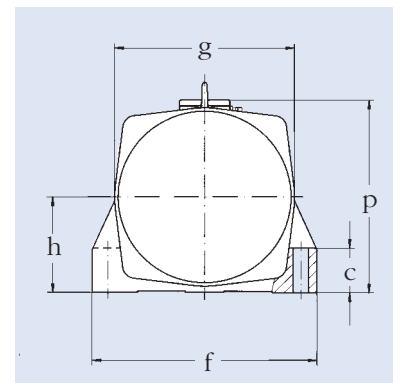
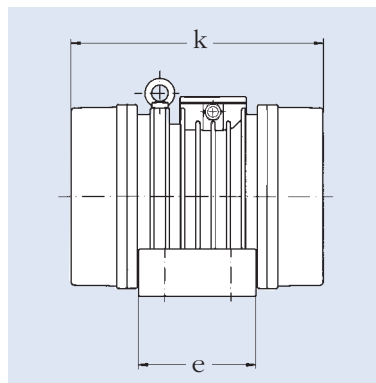
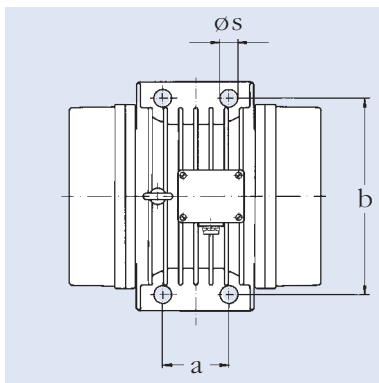

Model HV	Bores for fastening mm			Base measurements mm			Outside measurements mm				Mass kg
	a	b	ø <sub>s</sub>	c	e	f	h	g	p	k	
85/2	100	300	27	70	175	350	150	280	300	385	75
85/2-120	100	300	27	70	175	350	150	280	300	385	80
85/•-300	100	300	27	70	175	350	150	280	300	475	85
85/4-400	100	300	27	70	175	350	150	280	300	485	100
85/•-400	100	300	27	70	175	350	150	280	300	475	95



## Threephase Vibration Motor

This unit is used as mountable vibration motor in the most various machines. It is mounted between two holding flanges. The mounting position may be as desired. Tumbling vibration motors are admitted also.

The flyweights can be adapted as required for the existing application in view of adjustability and torque. They are not included in the delivery. The delivery of such equipment is optional.



The openly exposed flyweights must be enclosed by the client. In case of non-observation of this instruction, risk of accidents is impending. Required protective covers for the assembly of the mounting flanges can be delivered.



The individually manufactured bearings NJ 409 are lubricated with special grease and provides for long-time operation. Grease can be refilled into these bearings through outside grease nipples.

When allowing for the power input the motors can work continuously. As a means of protection for excessive heating up, cold conductors are provided also in the standard execution..

Standard voltage 400vs. · 50cps. Other voltages are available.

Protection class IP X4 · Insulant class F

Terminal box IP 65

Line	Model	Synchron. speed min <sup>-1</sup>	Centrif. force daN	Working moment cm kg	Changing of the centrifugal force		Standard voltage 50 cps. V	Nominal current A	Power input W
					inf. vari.	stepwise			
1	Supermat	3000	4050	82	–	1	3 ~ 400	8,0	4800
2			4300	86	2	–			
3			6100	129	2	–			

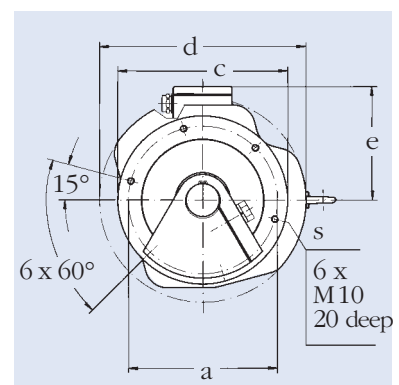
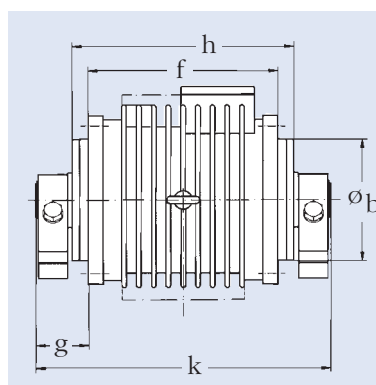
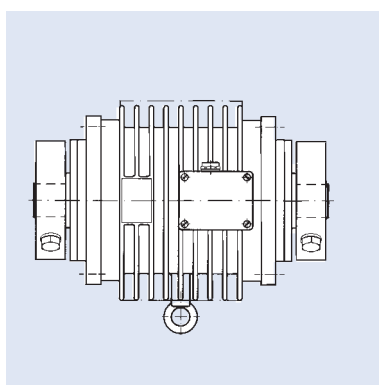

The figures show the flyweight according to line 1.

Model	Bores for fastening and flange measurements					linear measurements					Mass kg
	ø <sub>a</sub>	ø <sub>b<sub>k6</sub></sub>	s	ø <sub>c</sub>	ø <sub>d</sub>	e	f	g	h	k	
Supermat	202	166	M10	230	280	155	257	71,5	304	400	50



## Threephase Vibration Motor

These units are used as central drive in round screens and slide grinding systems ect.

The centrifugal flywheels can be displaced with respect to each other by 90° resp. 180°. In this manner a rotary and tumbling movement can be generated.

The extremely sturdy housing is manufactured from highly resistant, heat treated aluminium chill casting. The amply dimensioned bearings 629 ZZ C3 are lubricated for life. The centrifugal force can be changed by means of mountable eccentric weights. The vibrator can be run continuously with all the eccentric weights mounted, under consideration of the admissible power input.

Standard voltage 230/400vs.·50cps. Other voltages are available.

Type of protection IP 65·Insulant class F

Line	Model	Synchron. speed min <sup>-1</sup>	Centrif. force daN	Working moment cm kg	Changing of the centrifugal force		Standard voltage 50 cps. V	Nominal current A	Power input W
					inf. vari.	stepwise			
1	VFL 12/2	3000	600	12	–	8 ▲	3 ~ 230/400	2,3/1,33	650
2	VFL 12/4-18	1500	220	18	–	12 ▲	3 ~ 230/400	1,43/0,83	450
3	VFL 12/4-30	1500	375	30	–	20 ▲	3 ~ 230/400	1,43/0,83	450
4	VFL 12/4-42	1500	525	42	–	15 ▲	3 ~ 230/400	1,43/0,83	450

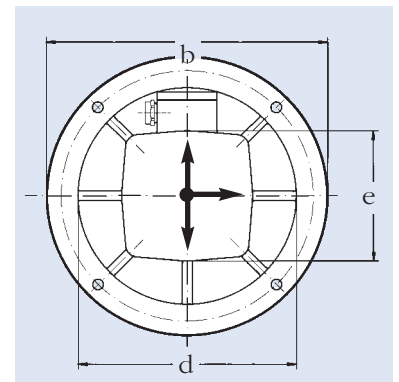
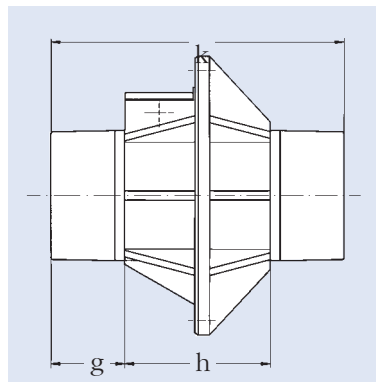
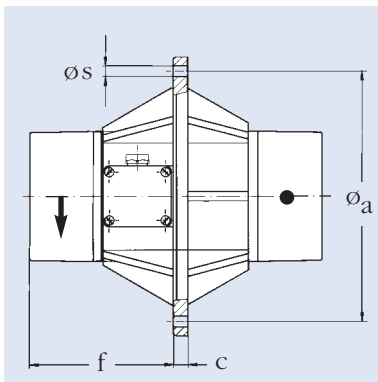

Model VFL	Befestigungs- und Flanschmaße					Längenmaße					Mass kg
	ø <sub>a</sub>	ø <sub>b<sub>h6</sub></sub>	ø <sub>s</sub>	c	ø <sub>d</sub>	e	f	g	h	k	
12/2	260	290	13	15	225	135	154	76,5	150	303	17,2
12/4-18	260	290	13	15	225	135	154	76,5	150	303	17,7
12/4-30	260	290	13	15	225	135	177,5	100,5	150	350	21,0
12/4-42	260	290	13	15	225	135	167,5	81,5	150	330	23,2



## Threephase Vibration Motor

Narrow construction without pedestal

These units had been devised where only little space is available, su as exist for assembly in ests of two in conveying channels. These units are mounted from the lower side through threaded bores.

The sturdy housing is manufactured from aluminium chill casting. The amply dimensioned bearings 6305 2Z C4 are lubricated for life. The centrifugal force can be changed stepwise by taking off the eccentric weights. The vibrator can be run continuously with all the eccentric weights mounted, under consideration of the admissible power consumption.

Standard voltage 230/400vs. · 50cps. Other voltages are available.

Type of protection IP 65 · Insulant class F



Line	Model	Synchron. speed min <sup>-1</sup>	Centrif. force daN	Working moment cm kg	Changing of the centrifugal force		Standard voltage 50 cps. V	Nominal current A	Power input W
					inf. vari.	stepwise			
1	HV 12/2 o.F.	3000	600	12	–	8 ▲	3 ~ 230/400	2,3/1,33	650
2	HV 12/4-18 o.F.	1500	220	18	–	12 ▲	3 ~ 230/400	1,43/0,83	450
3	HV 12/4-30 o.F.	1500	375	30	–	20 ▲	3 ~ 230/400	1,43/0,83	450
3	HV 12/4-42 o.F.	1500	255	42	–	15 ▲	3 ~ 230/400	1,43/0,83	450

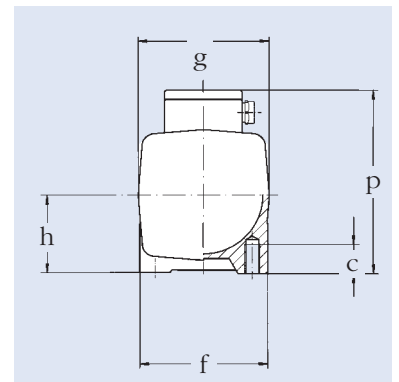
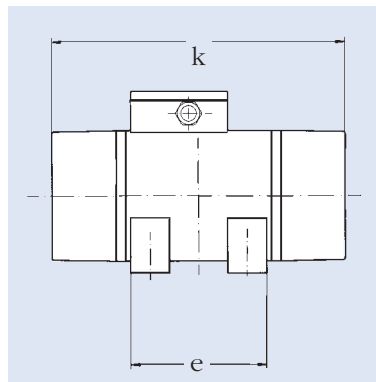
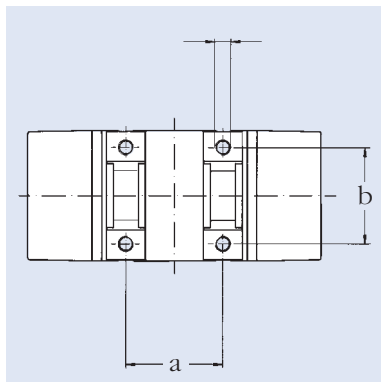

Model HV	Bores for fastening mm			Base measurements mm			Outside measurements mm				Mass kg
	a	b	M	c	e	f	h	g	p	k	
12/2 o.F.	100	100	M16	30	140	132	80	135	190	303	15,0
12/4-18 o.F.	100	100	M16	30	140	132	80	135	190	303	15,5
12/4-30 o.F.	100	100	M16	30	140	132	80	135	190	350	18,8
12/4-42 o.F.	100	100	M16	30	140	132	80	135	190	330	21

THE PROBLEM

Vibrating of variable masses with steady centrifugal forces and vibration with unchanged speed

THE SOLUTION

2MV-UNBALANCE SYSTEMS

Patent No. 4 225 564

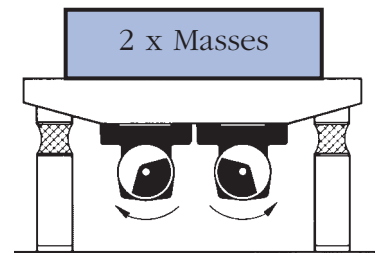
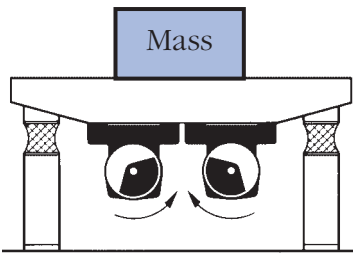
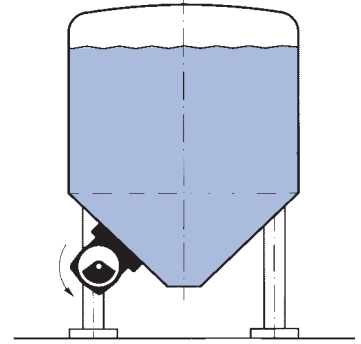
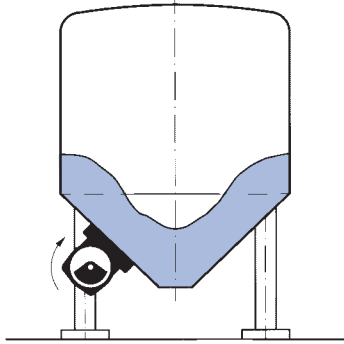

Without external influence, 2 MV vibration motors can generate two vibration strengths of constant speed, due to the sturdy mechanism.

two units, running in adverse direction with respect to each other. Here the mirror image location of the motors in pairs must be observed.

This happens quite easily by changing the sense of revolution with a pole reversing switch or little additional application of force with an electric control unit. Here, it is possible to change over directly from right-hand travel to left-hand travel.

Even the speed control by means of a frequency converter can become possible under reservation. But here, it must be renounced on smooth running of the motors.

With left-hand travel the maximum values are existing. With right-hand travel we have the reduced vibration values.

Thus, for instance, it is possible to work with 3000 vibrations a minute, with left-hand revolution, whereas with right-hand revolution and small torque, working is possible with 6000 revolutions a minute.

In addition, directed vibrations can be generated with the 2 MV unbalance system in the known manner with

Other interesting remarks concerning the speed control are given on page 24.

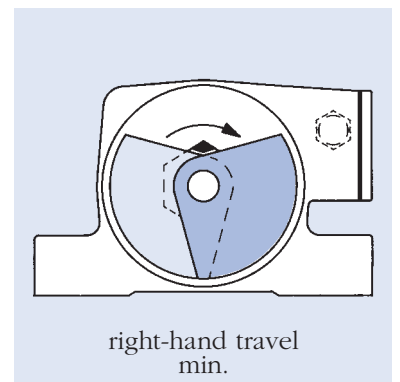
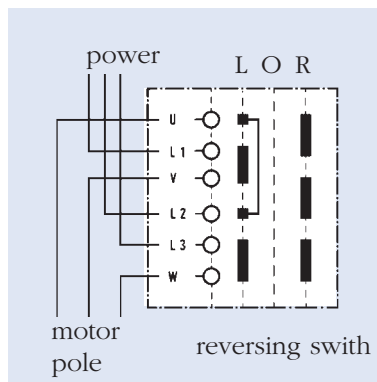
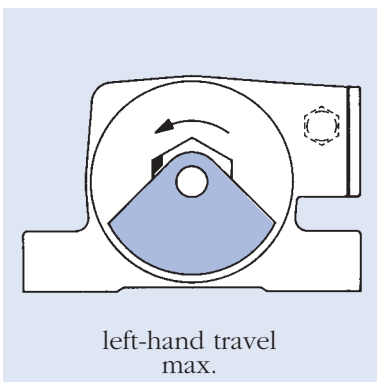

The 2 MV unbalance system can be mounted also in already available units by using 2 MV spares. See the

corresponding commission numbers. The application is limited to units with 3000 and 5000 revolutions.



## 2MV-Vibration Motors

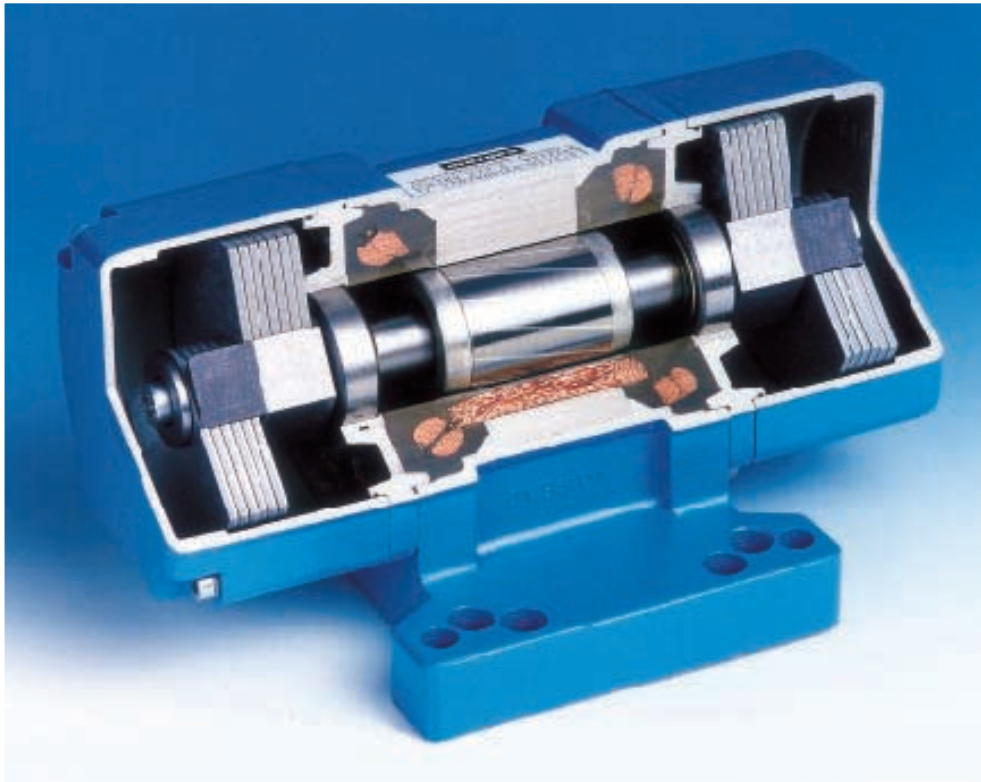

Model 2 MV 2/2-6

Speed min <sup>-1</sup>	Type	Centrif. Force <sup>2)</sup> (daN)		Torque <sup>2)</sup> (cmkg)		Other technical Data are given on page / line <sup>1)</sup>	2MV-Unbalance spares com. no.	Number of un- balance flywheels on each side <sup>2)</sup>
		min.	max.	min.	max.			
3000	2MV 2/2-2	66	132	1,4	2,8	page 7 / line 2	93155	3 + 3 flywheels
	2MV 2/2-6	132	264	2,8	5,6	page 7 / line 4	93170	6 + 6 flywheels
	2MV 8/2	190	380	3,8	7,6	page 12 / line 1	93300	5 + 5 flywheels
	2MV 12/2	300	600	6	12	page 13 / line 1	93350	4 + 4 flywheels
	2MV 15/2-20	525	1050	10,5	21	page 14 / line 2	93410	7 + 7 flywheels
	2MV 30/2	825	1650	16	32	page 15 / line 1	93510	7 + 7 flywheels
	2MV 55/2	1250	2500	25	50	page 16 / line 1	93550	6 + 6 flywheels
1500	2MV 2/4-2	16,5	33	1,4	2,8	page 7 / line 6	93155	3 + 3 flywheels
	2MV 2/4-6	33	66	2,8	5,6	page 7 / line 8	93170	6 + 6 flywheels
	2MV 2/4-9	55	110	4,5	9	page 7 / line 9	95175	10 + 10 flywheels
	2MV 6/4-18	105	210	8,5	17,0	page 10 / line 4	95264	11 + 11 flywheels
	2MV 12/4-42	245	490	19,5	39	page 13 / line 4	95380	7 + 7 flywheels

1) 2 MV units have unequal measures and power as the corresponding HV units.  
e.g. 2MV 2/2-2  $\hat{=}$  HV 2/2-2

2) Intermediate values are adjustable by using spacer wheels.  
Normal voltage 230/400vs · 50cps.  
Other voltages are available.



## Speed Control For Threephase Vibration Motor

Many operation processes with integrated vibration engineering function much better with an exactly adapted vibration frequency than only with standard speeds of 750, 1000, 1500 or 3000 rps. Using frequency converters, this can be actualized nowadays quite easily. But, for

this purpose, in most cases also an efficient control unit is necessary, which is exactly adapted to the requirements. In accordance with the requirements, these can be manufactured as hand-operated solutions as well as radio-controlled automatic systems.

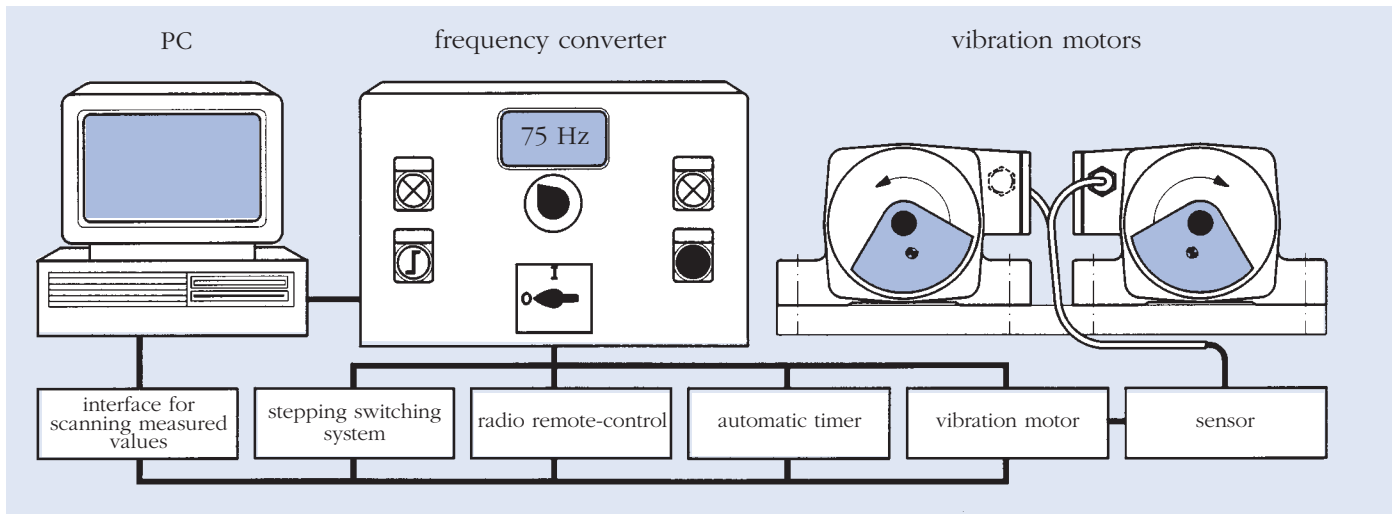

## Offer For Delivery

Along with the vibrations motors, WÜRGES can offer in exclusive responsibility for the proper function required, components, individually adapted turnkey circuits for the

control from one supplier. You need not look for suppliers for converters and manufacturers of control units.

## Important Hints

When selecting the required converter, it is necessary to allow for the power input of the vibrator. The power input can be found in the data sheet for the motor. Since vibration motors are equipment with a harder starting torque, WÜRGES recommend to select frequency converters with 1.8 – 2-fold power output in kVA referred to the motor input in kW.

e.g. vibration motor HV 15/2-20;  
power input 0,9 kW;  
required frequency converter  
ca.1.6 – 1.8 kVA.

Rotary current vibration motors can be controled under reservation with conventional frequency converters.



The speed reduction implies no problem. In case of speed increase in excess of the value indicated on the machine plate, danger of breakeage and accidents is impending by excessive centrifugal force. The control force is increased square with respect to the speed increase.

For this reason, we suggest to you that you enquire with us for hte tolerable maximum final speed of the motor concerned





## Electromagnetic Vibrators

The use of electromagnetic vibrators as eccentric weight vibrators is to be recommended in many fields of application, e.g. for filling, weighing, and batching equipment, as the circuit breaker avoids that filling product will follow after the disconnection. Our electromagnetic weight vibrators provide for directional vibrators without adopting any further measures.

Advantage: No rotating parts · free from wear · no maintenance · exclusion of twophase operation.



### MR

For 6000 vibrations a minute with 50cps. frequency of the power line. Voltage commutable to 230 or 400vs.

### GMR

These electromagnetic vibrators for 3000 vibrations a minute must be operated only with connected rectifier.

Type of protection IP 65 · Insulant class B

Line	Model	Vibrations min <sup>-1</sup>	Standard voltage 50 vs. V	Nominal current A	Power input VA
1	MR 1	6000	2 ~ 230/400	0,64/0,37	140
2	GMR 1	3000	2 ≈ 230/400	0,64/0,37	140

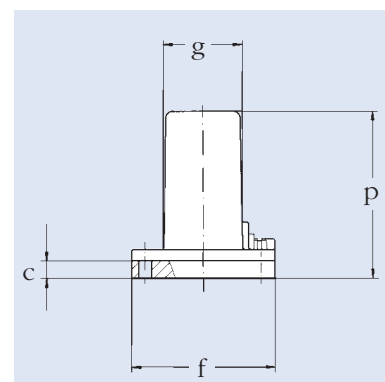
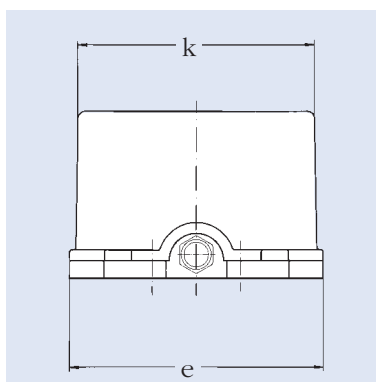
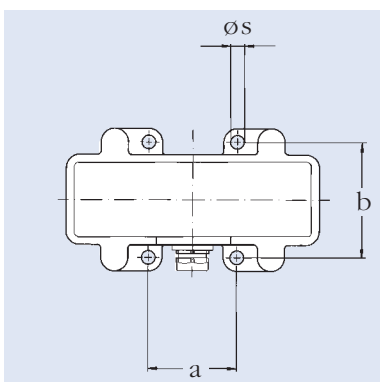

Model	Bores for fastening mm			Base measurements mm			Outside measurements mm				Mass kg
	a	b	ø <sub>s</sub>	c	e	f	h	g	p	k	
MR 1	65	85	9,5	13	185	105	–	56	123	176	3,5
GMR 1	65	85	9,5	13	185	105	–	56	123	176	3,5



Vario fastening hole 65 x 140



## Threephase Vibration Motors Explosion-proof

The sturdy housing is manufactured from aluminium chill casting. The amply dimensioned bearings 6305 2Z C4 are lubricated for life. The centrifugal force can be changed stepwise by taking off the eccentric weights. The vibrator can be run continuously with all the eccentric weights mounted, under consideration of the admissible power consumption. Including 2 m of power cable NSSHÖU-J 4 x 1,5<sup>2</sup>, ø 13,5mm.

Standard voltage 400vs · 50cps. Other voltages available.

These units have no commutable poles.

Type of protection IP 65 · EEx e II T3 · Insulant class B, suitable for two zones 1, 2, 10, 11. According to the VDE 0165 (VDE = association of German electricians)

Line	Model	Synchron. speed min <sup>-1</sup>	Centrif. force daN	Working moment cm kg	Changing of the centrifugal force		Standard voltage 50 cps. V	Nominal current A	Power input W
					inf. vari.	stepwise			
1	HVE 2/2	3000	88	1,85	–	4 ▲	3 ~ 400	0,34	200
2	HVE 2/2-2	3000	132	2,8	–	6 ▲	3 ~ 400	0,34	200
3	HVE 2/2-4	3000	176	3,7	–	8 ▲	3 ~ 400	0,34	200
4	HVE 2/2-6	3000	286	6	–	13 ▲	3 ~ 400	0,34	200
5	HVE 2/4	1500	22	1,85	–	4 ▲	3 ~ 400	0,29	120
6	HVE 2/4-2	1500	33	2,8	–	6 ▲	3 ~ 400	0,29	120
7	HVE 2/4-4	1500	44	3,7	–	8 ▲	3 ~ 400	0,29	120
8	HVE 2/4-6	1500	71,5	6	–	13 ▲	3 ~ 400	0,29	120
9	HVE 2/4-9	1500	110	9	–	20 ▲	3 ~ 400	0,29	120

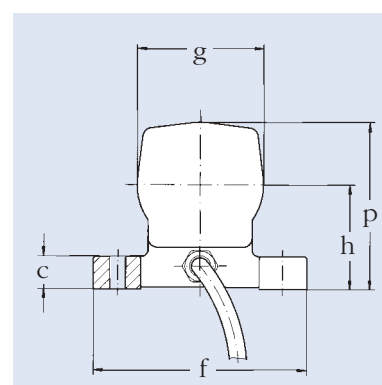
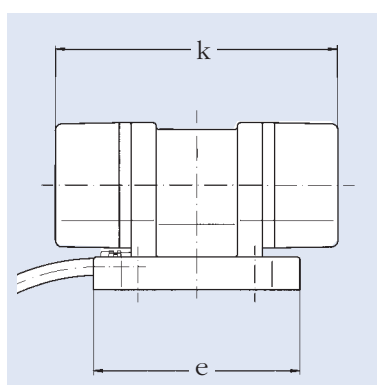
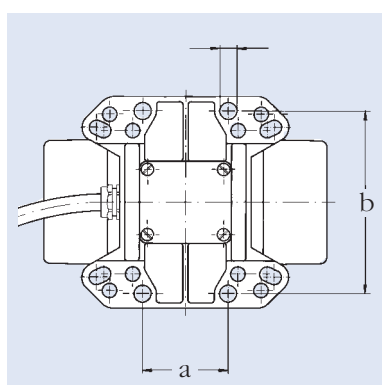

Model HVE	Bores for fastening <sup>1</sup> mm			Base measurements mm			Outside measurements mm				Mass kg
	a	b	ø <sub>s</sub>	c	e	f	h	g	p	k	
2/•	$\left. \begin{matrix} 65 & 140 & 13 \\ 80 & 110 & 11 \\ 115 & 135 & 11 \\ 135 & 115 & 11 \\ 124 & 110 & 11 \end{matrix} \right\}$	25	157	162	80	96	128	189	5,6		
2/•-2		25	157	162	80	96	128	201	5,9		
2/•-4		25	157	162	80	96	128	215	6,4		
2/•-6		25	157	162	80	96	128	250	7,1		
2/4-9		25	157	162	80	96	128	283	8,1		

<sup>1</sup> All mentioned fastening holes are provided in the unit.





## Threephase Vibration Motors Explosion-proof

The sturdy housing is manufactured from aluminium chill casting. The amply dimensioned bearings 6305 2Z C4 are lubricated for life. The centrifugal force can be changed stepwise by taking off the eccentric weights. The vibrator can be run continuously with all the eccentric weights mounted, under consideration of the admissible power consumption.

Standard voltage 400vs · 50cps. Other voltages available.

These units have no commutable poles.

Type of protection IP 65 · EEx e II T4 · Insulant class F, suitable for two zones 1, 2, 10, 11. According to the VDE 0165 (VDE = association of German electricians)



Line	Model	Synchron. speed min <sup>-1</sup>	Centrif. force daN	Working moment cm kg	Changing of the centrifugal force		Standard voltage 50 cps. V	Nominal current A	Power input W
					inf. vari.	stepwise			
1	HVE 9/2	3000	600	12	–	8 ▲	3 ~ 400	0,69	420
2	HVE 9/4-18	1500	220	18	–	12 ▲	3 ~ 400	0,86	450
3	HVE 9/4-30	1500	375	30	–	20 ▲	3 ~ 400	0,86	450

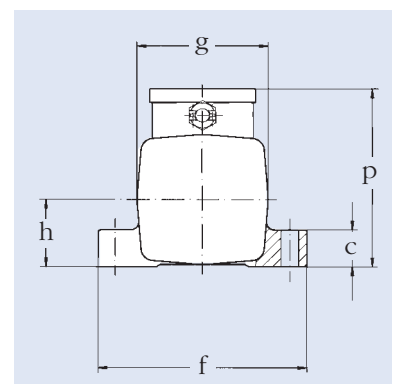
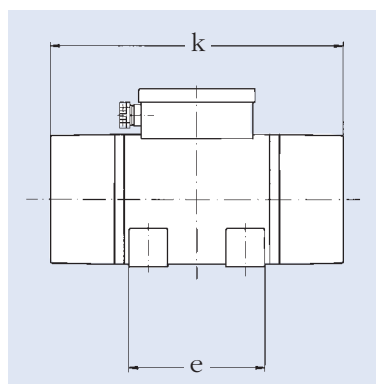
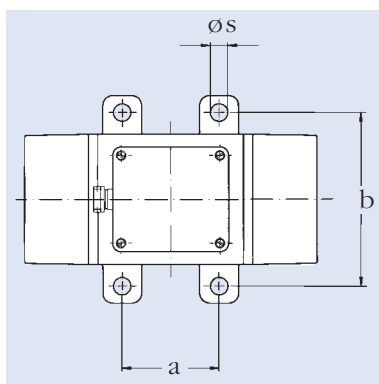

Model	Bores for fastening mm			Base measurements mm			Outside measurements mm				Mass kg
	a	b	ø <sub>s</sub>	c	e	f	h	g	p	k	
9/2	100	180	18	40	140	215	70	135	189	303	16,7
9/4-18	100	180	18	40	140	215	70	135	189	303	17,3
9/4-30	100	180	18	40	140	215	70	135	189	350	20,5





## Monophase A.C. Vibraton Motor

A.C. vibrators are used in locations, where no threephase current is available. They are most suitable for table vibrators and the like, as they can work with up to 5000 rpm. without frequency converter. The speed can be regulated down to approximately 2000rpm.

The housing of these vibrators is manufactured from aluminium chill casting. The centrifugal force can be changed stepwise by mountable eccentric weights.

Standard voltage 230vs. · 50–60cps.

Type of protection IP 65 · Insulant class B

Line	Model	Synchron. speed min <sup>-1</sup>	Centrif. force daN	Working moment cm kg	Changing of the centrifugal force		Voltage 50 – 60 cps. 1 ~ V	Nominal current A	Power input W
					inf. vari.	stepwise			
1	HV 6 W	5000	240	1,85	–	4 ▲	1 x 230	1	230

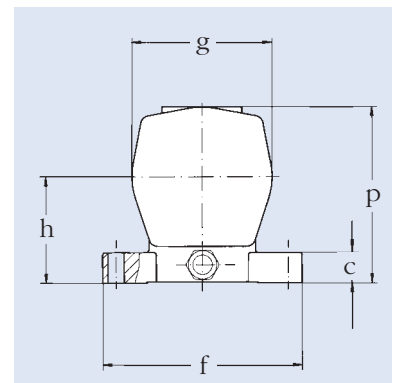
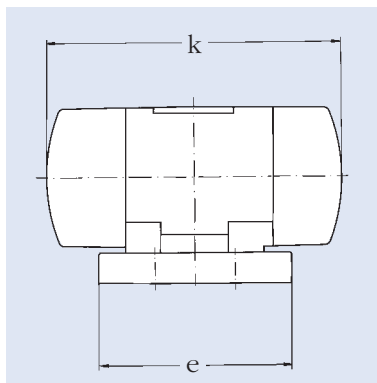
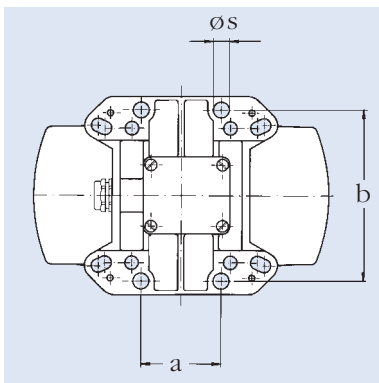

Model	Bores for fastening <sup>1</sup> mm			Base measurements mm			Outside measurements mm				Mass kg
	a	b	ø <sub>s</sub>	c	e	f	h	g	p	k	
HV 6 W	$\left\{ \begin{array}{l} 65 \quad 140 \quad 13 \\ 80 \quad 110 \quad 11 \\ (115 \quad 135 \quad 11) \\ 135 \quad 115 \quad 11 \\ 124 \quad 110 \quad 11 \end{array} \right\}$			25	157	162	86	114	144	240	6,3

<sup>1</sup> All mentioned fastening holes are provided in the unit.



## D.C. Vibration Motor

D.C. vibrators are used for machines and equipment which work with internal combustion engines.

Power supply will be effected with 12 or 24 volts by means of the battery.

The housing of these vibrators is manufactured from aluminium chill casting. The centrifugal force can be changed stepwise by mountable eccentric weights.

Type of protection IP 65 · Insulant class B



Line	Model	Synchron. speed min <sup>-1</sup>	Centrif. force daN	Working moment cm kg	Changing of the centrifugal force		Voltage D.C. V	Nominal current A	Power input W
					inf. vari.	stepwise			
1	HV 6 GL-12	3300	140	2,35	–	5 ▲	= 12	10	120
2	HV 6 GL-24	3300	140	2,35	–	5 ▲	= 24	7	168

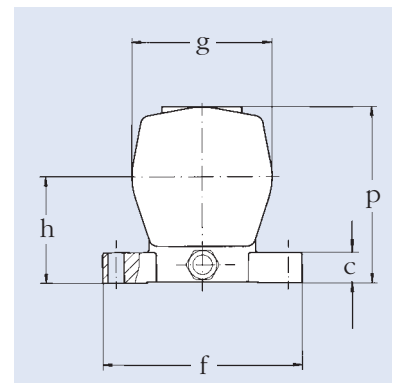
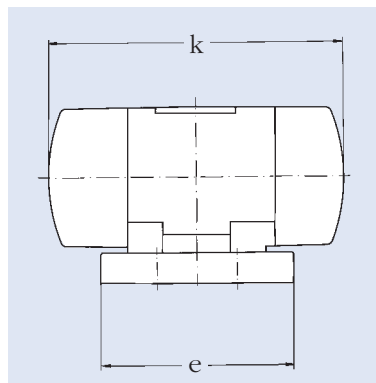
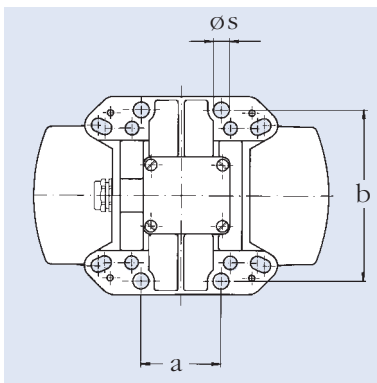

Model	Bores for fastening <sup>1</sup> mm			Base measurements mm			Outside measurements mm				Mass kg
	a	b	ø <sub>s</sub>	c	e	f	h	g	p	k	
HV 6 GL	$\left\{ \begin{array}{l} 65 \quad 140 \quad 13 \\ 80 \quad 110 \quad 11 \\ (115 \quad 135 \quad 11) \\ 135 \quad 115 \quad 11 \\ 124 \quad 110 \quad 11 \end{array} \right\}$			25	157	162	86	114	144	240	7,2

<sup>1</sup> All mentioned fastening holes are provided in the unit.





## External Vibrators Of High Frequency

External vibrators of high frequency can be run only with high frequency of 200cps. These vibrators are prevailingly used in the construction industry for concrete compaction with moulds and formwork.

The sturdy housing is manufactured from aluminium chill casting. The amply dimensioned bearings 6305 2Z C4 are lubricated for life. The centrifugal force can be changed in four steps by taking off the eccentric weights. The vibrator can be run continuously with all the eccentric weights mounted, under consideration of the admissible power input consumption.

The winding is completely sealed. Due to this, there is a quick dissipation of heat, which almost excludes burning out.

Type of protection IP 65 · Insulant class F

Standard voltages 250vs., 48vs. or 42vs only for 200cps.

Other voltages available.

Line	Model	Synchron. speed min <sup>-1</sup>	Centrif. force daN	Working moment cm kg	Changing of the centrifugal force		Nominal current 200 cps. 3~		Power input VA
					inf. vari.	stepwise	42 vs. A	250 vs. A	
1	HF 1/4	6000	100	0,5	–	3 ▲	5,0	0,85	365

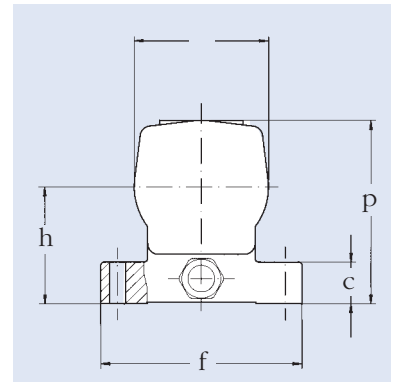
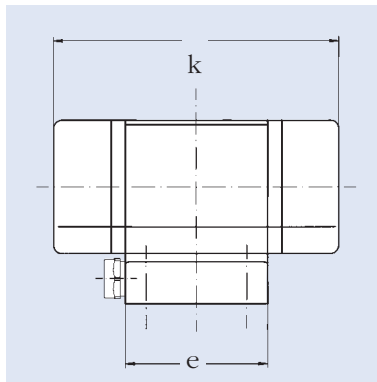
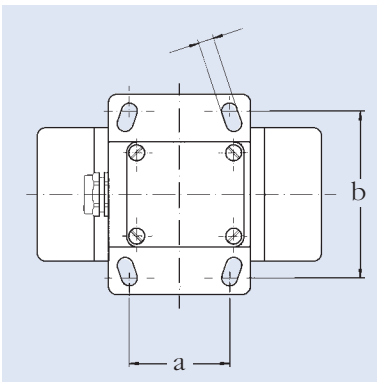

Model	Bores for fastening <sup>1</sup> mm			Base measurements mm			Outside measurements mm				Mass kg
	a	b	ø <sub>s</sub>	c	e	f	h	g	p	k	
HF 1/4	$\left\{ \begin{array}{l} 60 \quad 100 \quad 9,5 \\ 65 \quad 85 \quad 9,5 \end{array} \right\}$			25	85	120	70	80	110	170	3,6

<sup>1</sup> All mentioned fastening holes are provided in the unit.



## External Vibrators Of High Frequency

External vibrators of high frequency can be run only with high frequency of 200cps. These vibrators are prevailingly used in the construction industry for concrete compaction with moulds and formwork.

The sturdy housing is manufactured from aluminium chill casting. The amply dimensioned bearings 6303 2Z C4 are lubricated for life. The centrifugal force can be changed stepwise by taking off the eccentric weights. The vibrator can be run continuously with all the eccentric weights mounted, under consideration of the admissible power input consumption.

Type of protection IP 65 · Insulant class F

Standard voltages 250vs., 48vs. or 42vs only for 200cps.  
Other voltages available.



Line	Model	Synchron. speed min <sup>-1</sup>	Centrif. force daN	Working moment cm kg	Changing of the centrifugal force		Nominal current 200 cps. 3~		Power input VA
					inf. vari.	stepwise	42 vs. A	250 vs. A	
1	HF 6/4	6000	305	1,5	–	2 ▲	6,5	1,1	475
2	HF 6/8	3000	305	6,1	–	8 ▲	9,5	1,6	690

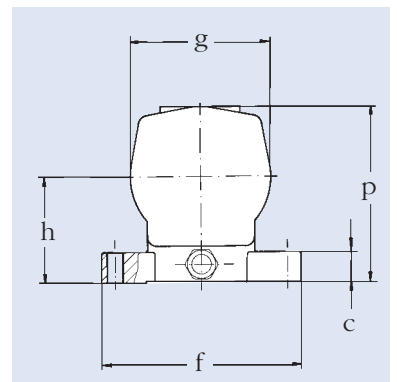
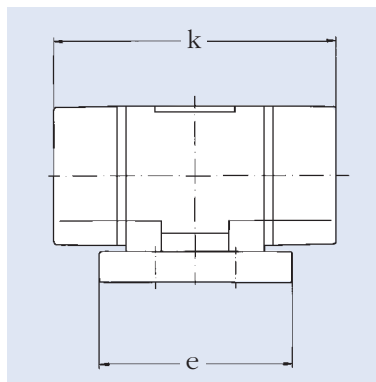
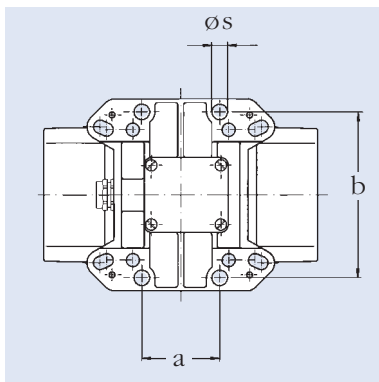

Model	Bores for fastening <sup>1</sup> mm			Base measurements mm			Outside measurements mm				Mass kg
	a	b	ø <sub>s</sub>	c	e	f	h	g	p	k	
HF 6/4	$\left\{ \begin{array}{l} 65 \\ 80 \\ (115) \\ 124 \\ 135 \end{array} \right.$	140	13	25	157	162	86	114	144	270	7,4
HF 6/8		110	11								
		135	11								
		110	11								
		115	11								7,6

<sup>1</sup> All mentioned fastening holes are provided in the unit.





## External Vibrators Of High Frequency

External vibrators of high frequency can be run only with high frequency of 200cps. These vibrators are prevailingly used in the construction industry for concrete compaction with moulds and formwork.

The sturdy housing is manufactured from aluminium chill casting. The amply dimensioned bearings NJ 2305 E M C4 are lubricated for life. The centrifugal force can be changed in four steps by taking off the eccentric weights. The vibrator can be run continuously with all the eccentric weights mounted, under consideration of the admissible power consumption.

The winding is completely sealed. Due to this, there is a quick dissipation of heat, which almost excludes burning out.

Type of protection IP 65 · Insulant class F

Standard voltages 250vs., 48vs. or 42vs only for 200cps.  
Other voltages available.

Line	Model	Synchron. speed min <sup>-1</sup>	Centrif. force daN	Working moment cm kg	Changing of the centrifugal force		Nominal current 200 cps. 3~		Power input VA
					inf. vari.	stepwise	42 vs. A	250 vs. A	
1	HF 15/4	6000	1200	6,15	–	5 ▲	16,5	2,8	1200

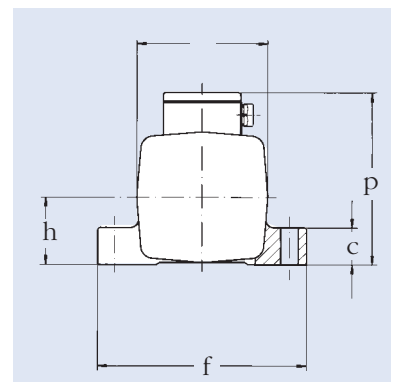
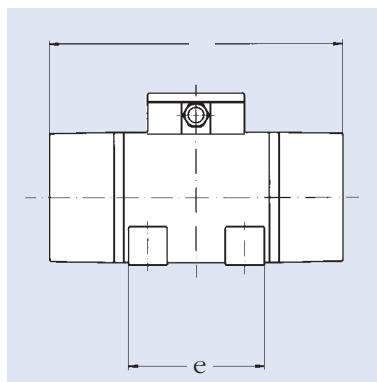
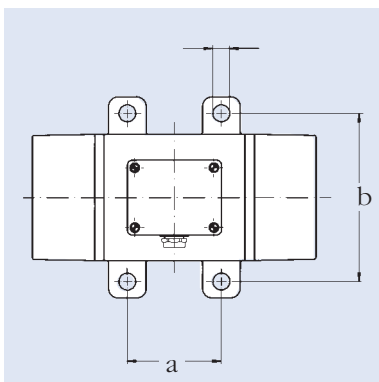

Model	Bores for fastening mm			Base measurements mm			Outside measurements mm				Mass kg
	a	b	ø <sub>s</sub>	c	e	f	h	g	p	k	
HF 15/4	100	180	18	40	140	215	70	135	180	302	16,1







## Oscillating Converters for Linear Oscillations

### The Problem:

Aligned oscillations are necessary for a number of vibratory processes. They are usually generated by two vibration motors mounted in parallel and rotating opposite one another. Under certain circumstances, the synchronisation of the two motors does not always function properly. The oscillating system has to be able to oscillate on at least two axes freely in the start-up phase. However, in such things as restricted guidance, this is not the case.

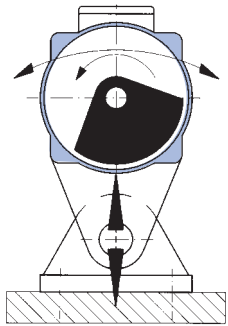
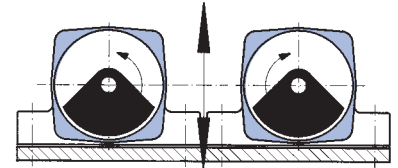

### The Expensive Solution:

You can easily correct the problem with an oscillating vibrator that unites the power of two motors working in the opposite direction. Since they are special constructions, oscillating vibrators are relatively expensive and only broken down roughly in their power stages. They are not a part of our scope of supply.

### Our Cost-effective Solution:

Our alternative is oscillating converters in connection with standard vibration motors. Both devices are simply screwed together with one another. They function in a similar fashion to oscillating vibrators, but with the advantage of a wide variety of detailed power stages to choose from.

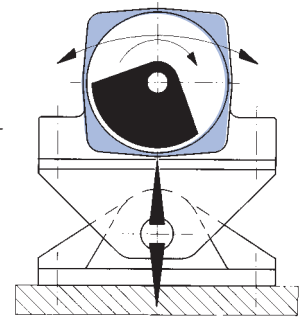

Line	Model	Vibration Motors that match the Oscillating Converters	Mass (kg)
1	SR - 2	HV 2, HVE 2, HV 6 D, HV 6 GL, HV 6 W und HF 6	3,15
2	SR - 15	HV 8, HVE 9, HV 12, HV 15, und HF15	6,9
3	SR - 30	HV 30	7,25
4	SR - 55	HV 55, HV 65	28,0

The screws for fastening the motor are a part of the scope of delivery.

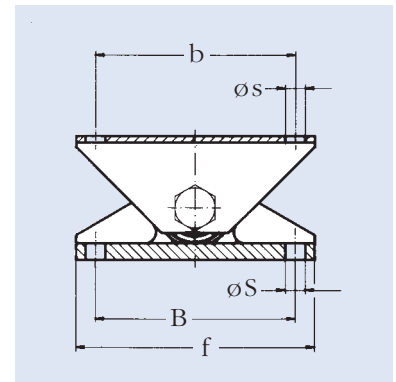
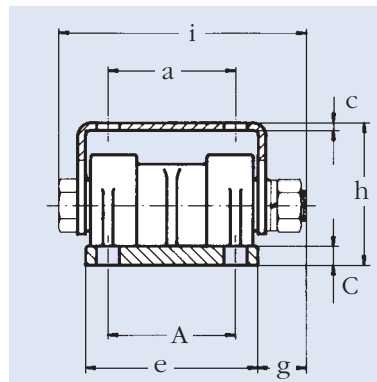
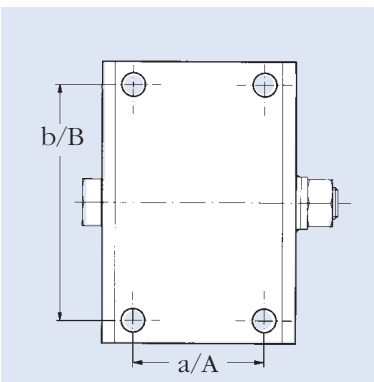

Model	mounting dimensions for the vibration motor in mm				fastening dimensions for the oscillating converter in mm				exterior dimensions for the oscillating converter in mm				
	a	b	ø <sub>S</sub>	c	A	B	ø <sub>S</sub>	C	e	f	g	i	h
SR - 2	65	140	13	6	65	140	13	10	120	163	8	135	73
SR - 15	100	180	18	6	100	180	18	15	135	215	38	195	112
SR - 30	100	200	18	6	100	180	18	15	135	215	38	195	122
SR - 55	120	250	M20	20	160	160	18	15	280	195	40	360	165

## Operating Instructions for Oscillating Converters

### 1. Safety Information

These operating instructions have to be read and understood by every person in the operator's company who is entrusted with the task of installing, starting up, servicing and repairing vibration motors with oscillating converters.

The corresponding operating instructions of the vibration motor used together with the oscillating converter has to also be consulted for a better understanding of these operating instructions.

### 2. Intended Use

Oscillating converters are only designed for use in vibration technology as connecting links between vibration motors and utility devices. All use going beyond this shall be deemed as non-intended use.

### 3. Structure

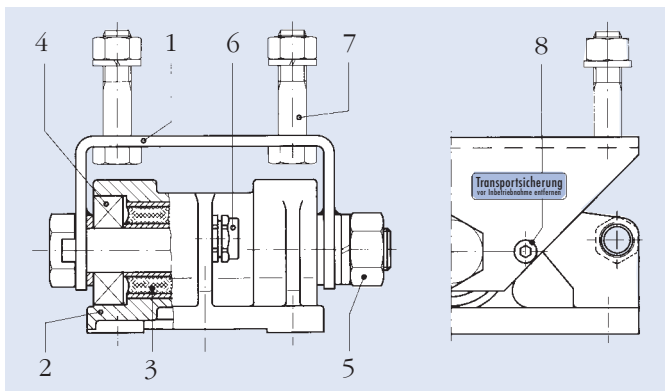

1. upper part for fitting the motor
2. lower part for fastening the utility device
3. the torsion sleeve
4. bearings
5. the shaft with the tension screws or nuts
6. the cable screwed connections
7. the screws for fastening the vibration motor
8. the transportation securing device

The upper part is lodged soft bending in the torsion sleeve opposite the lower part towards the side. It is connected vertically with the lower part free of backlash above the ball bearing and shaft.

### 4. How It Functions

The circular oscillation of the vibration motor is transmitted almost linearly through the converter to the utility device. Only the oscillations occurring horizontally to the motor fastening surface are passed onto the lower part. The transverse oscillation is run out from the upper part.

### 5. Instructions for Mounting

First of all, the vibration motor has to be screwed together with the oscillating converter. Please use the screws included for this (item 7) and fasten them with the appropriate torque (refer to the operating instructions for vibration motors, the section on mounting information).

Now the motor and oscillating converter can be built onto the utility device.

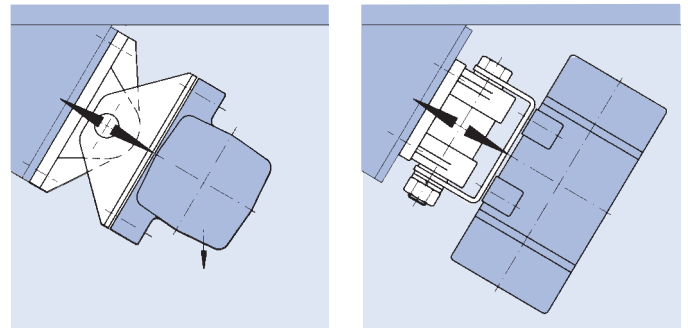

The mounting position as in Figure 2 with a vertical motor is preferable because the torsion sleeve is under less load.

The fastening surface for the oscillating converter has to be flat and stiff to bending so that the lower part cannot be deformed. Use quality class 8.8 fastening screws and quality class 6 nuts, secure them with split washers and tighten them with the same torsion as earlier when fastening the motor.

### 6. Information on the Electrical Connection

Connect the cable in accordance with the operating instructions for the motor and always use the heavy rubber hose line NSSHÖU-J as stated. The cable should be put through the cable screwed connections on the lower part again in a tight arch to avoid damaging natural oscillations.

### 7. Instructions for First Start Up



The upper part of the oscillating converter was rigidly fixed onto the lower part with a transportation securing screw at the factory. Therefore, you should always remove this screw before starting up as stated on the glued on sign. Check the connecting line for impermissible resonating oscillation and chafe marks during operation and change the cable's position if necessary.

### 8. Storage and Transportation

The transportation securing device may be temporarily re-mounted during transportation. However, you should also make reference to this hazard point action in your own operating instructions in accordance with Point 7.



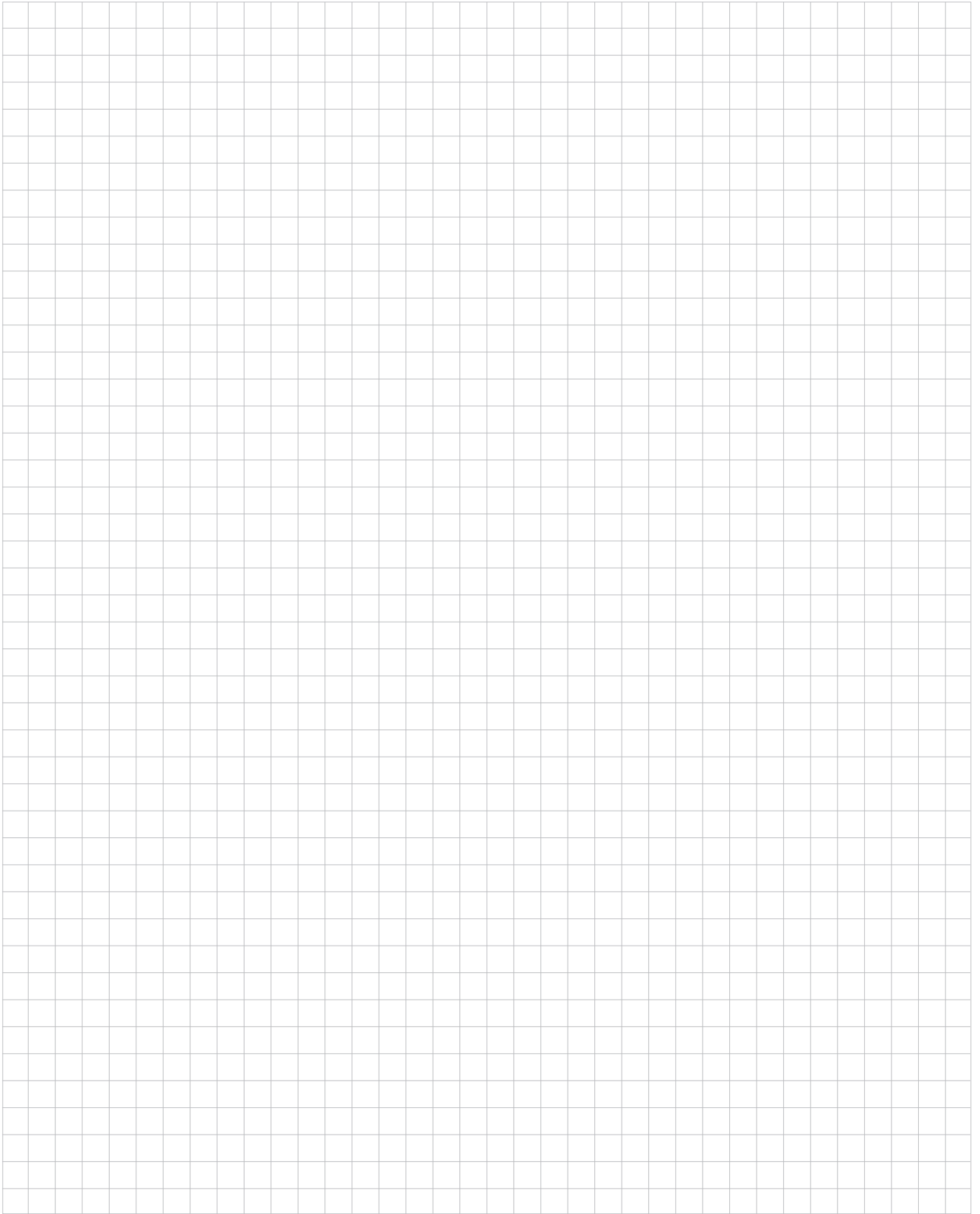

**würges**

WÜRGES  
Vibrationstechnik GmbH  
D-86356 Neusäß / Augsburg  
Daimlerstraße 9  
Telefon 08 21/ 46 30 81  
Telefax 08 21/ 46 30 84  
e-Mail: [info@wuerges.de](mailto:info@wuerges.de)  
Internet: [www.wuerges.de](http://www.wuerges.de)

